



Developer Note

The iMac Family of Computers



Technical Publications
© Apple Computer, Inc. 1999

🍏 Apple Computer, Inc.

© 1999 Apple Computer, Inc.

All rights reserved.

No part of this publication may be reproduced, stored in a retrieval system, or transmitted, in any form or by any means, mechanical, electronic, photocopying, recording, or otherwise, without prior written permission of Apple Computer, Inc., except to make a backup copy of any documentation provided on CD-ROM.

The Apple logo is a trademark of Apple Computer, Inc.

Use of the “keyboard” Apple logo (Option-Shift-K) for commercial purposes without the prior written consent of Apple may constitute trademark infringement and unfair competition in violation of federal and state laws.

No licenses, express or implied, are granted with respect to any of the technology described in this book. Apple retains all intellectual property rights associated with the technology described in this book. This book is intended to assist application developers to develop applications only for Apple-labeled or Apple-licensed computers.

Every effort has been made to ensure that the information in this manual is accurate. Apple is not responsible for typographical errors.

Apple Computer, Inc.
1 Infinite Loop
Cupertino, CA 95014
408-996-1010

Apple, the Apple logo, FireWire, the FireWire logo, Macintosh, and Power Macintosh are trademarks of Apple Computer, Inc., registered in the United States and other countries.

AirPort and iMac are trademarks of Apple Computer, Inc.

Adobe, Acrobat, and PostScript are trademarks of Adobe Systems Incorporated or its subsidiaries and

may be registered in certain jurisdictions.

Helvetica and Palatino are registered trademarks of Linotype-Hell AG and/or its subsidiaries.

ITC Zapf Dingbats is a registered trademark of International Typeface Corporation.

PowerPC is a trademark of International Business Machines Corporation, used under license therefrom.

Simultaneously published in the United States and Canada.

Even though Apple has reviewed this manual, APPLE MAKES NO WARRANTY OR REPRESENTATION, EITHER EXPRESS OR IMPLIED, WITH RESPECT TO THIS MANUAL, ITS QUALITY, ACCURACY, MERCHANTABILITY, OR FITNESS FOR A PARTICULAR PURPOSE. AS A RESULT, THIS MANUAL IS SOLD “AS IS,” AND YOU, THE PURCHASER, ARE ASSUMING THE ENTIRE RISK AS TO ITS QUALITY AND ACCURACY.

IN NO EVENT WILL APPLE BE LIABLE FOR DIRECT, INDIRECT, SPECIAL, INCIDENTAL, OR CONSEQUENTIAL DAMAGES RESULTING FROM ANY DEFECT OR INACCURACY IN THIS MANUAL, even if advised of the possibility of such damages.

THE WARRANTY AND REMEDIES SET FORTH ABOVE ARE EXCLUSIVE AND IN LIEU OF ALL OTHERS, ORAL OR WRITTEN, EXPRESS OR IMPLIED. No Apple dealer, agent, or employee is authorized to make any modification, extension, or addition to this warranty.

Some states do not allow the exclusion or limitation of implied warranties or liability for incidental or consequential damages, so the above limitation or exclusion may not apply to you. This warranty gives you specific legal rights, and you may also have other rights which vary from state to state.

Contents

Figures and Tables 7

Preface About This Developer Note 9

Contents of This Note 9
Supplemental Reference Documents 10
 3D Graphics 10
 PowerPC G3 Microprocessor 10
 RAM Expansion Modules 11
 ATA Devices 11
 USB Interface 11
 FireWire Interface 12
 Mac OS 8.6 12
 Open Firmware 13

Chapter 1 Introduction 15

Model History 16
Features 17
External Features 19
Compatibility Issues 20
 Main RAM Expansion Modules 20
 USB Ports and Devices 20

Chapter 2 Architecture 23

Block Diagram and Buses 24
 Block Diagram 24
 Main ICs and Buses 26
Microprocessor and Cache 26
 G3 Microprocessor 26
 Backside Cache 27
Memory Controller and Bus Bridge 27

System RAM	28
Boot ROM	28
FireWire Controller	28
Ethernet Controller	28
Video Display Subsystem	29
I/O Device Controller	29
DMA Support	30
Interrupt Support	30
USB Interface	30
Ultra DMA Interface	31
Modem Support	31
Sound IC Support	32
Power Controller	32
Wireless LAN Module	32

Chapter 3 Devices and Ports 33

USB Ports	34
USB Connectors	34
USB Features	35
Power Off During Sleep	35
Connect and Resume	36
USB Storage Devices	36
USB Controller	36
USB Compatibility Issues	37
ADB Compatibility	37
Serial Port Compatibility	37
Not for Networking	38
FireWire Ports	38
FireWire Connector	38
Ethernet Port	40
Internal Modem	41
AirPort Card Wireless LAN Module	42
Data Security	42
Hardware Components	42
Software Components	43
Hard Disk Drive	44
CD-ROM Drive	44

DVD-ROM Drive	44
Video Display	45
Video Monitor Port	46
Monitor Connector	46
Keyboard	47
Keyboard Layout	47
Keyboard and USB	48
Mouse	49
Sound System	49
Sound Inputs	49
Built-in Microphone	50
External Sound Input Jack	50
Sound Outputs	50
Internal Speakers	50
External Sound Output	51
Headphone Jacks	51
Sound Specifications	51

Chapter 4 RAM Expansion 53

RAM Expansion Slots	54
RAM Expansion Modules	54
Mechanical Design of RAM DIMMs	55
Electrical Design of RAM DIMMs	55
DIMM Configurations	56
RAM Addressing	57

Chapter 5 Software 59

ROM in RAM	60
Aspects of the New Approach	60
RAM Footprint	60
Startup Disk Control Panel	61
Data Structures and Files	61
Memory Mapping	61
Boot Process	62
Boot ROM Contents	63

Hardware Initialization Code	63
Open Firmware	64
Interrupts	64
Mac OS ROM Image File	64
System Software Modifications	65
Computer Identification	65
Power Saving Modes	66
ATA Manager 4.0	67
USB Drivers	67
Other New Drivers	68
Legacy Drivers	68
ADB Legacy	68
SCSI Legacy	69

Appendix A Abbreviations	71
--------------------------	----

Index	75
-------	----

Figures and Tables

Chapter 1	Introduction	15	
	Table 1-1	Feature differences	16
Chapter 2	Architecture	23	
	Figure 2-1	Block diagram	25
	Table 2-1	Buses supported by the Uni-N IC	27
Chapter 3	Devices and Ports	33	
	Figure 3-1	USB Type A port and pins	35
	Figure 3-2	FireWire connector	39
	Figure 3-3	Video connector	46
	Figure 3-4	ANSI keyboard layout	48
	Table 3-1	Pin assignments on the USB port	35
	Table 3-2	Pin assignments on the FireWire connector	39
	Table 3-3	Signals on the Ethernet connector	41
	Table 3-4	Display resolutions and pixel depths	45
	Table 3-5	Signals on the video connector	46
	Table 3-6	Distortion specifications	52
	Table 3-7	SNR specifications	52
Chapter 4	RAM Expansion	53	
	Table 4-1	Sizes of RAM expansion devices and modules	56
	Table 4-2	Address multiplexing modes for SDRAM DIMMs	57

About This Developer Note

This developer note gives a technical description of the all-new iMac family of computers, including the changes that have been made since the introduction of the original iMac in the summer of 1998.

This developer note is intended to help hardware and software developers design products that are compatible with the products described here. If you are not already familiar with Macintosh computers or if you would simply like additional technical information, you may wish to read the section “Supplemental Reference Documents”.

This note is published only in electronic form, as an Adobe™ Acrobat™ PDF (portable document file) and in HTML for browsers that support frame sets. The file is available from two sources:

- on the World Wide Web at
<http://developer.apple.com/techpubs/hardware/hardware.html>
- on the Reference Library Edition of the Developer CD Series, which is distributed as part of the monthly mailing to registered developers

Contents of This Note

The information in this note is arranged in five chapters and an appendix.

- Chapter 1, “Introduction,” introduces the iMac family of computers and describes their features.
- Chapter 2, “Architecture,” describes the internal logic of the computer, including the main ICs.
- Chapter 3, “Devices and Ports,” describes the I/O ports and the built-in I/O devices.
- Chapter 4, “RAM Expansion,” describes the expansion features of interest to developers. It includes development guides for the RAM expansion modules.

- Chapter 5, “Software,” describes the system software that comes with the computer, with emphasis on the ROM-in-RAM and Open Firmware features.
- Appendix A lists the abbreviations used in the developer note.

Supplemental Reference Documents

For more information about the technologies mentioned in this developer note, you may wish to consult some of the following references.

Developers should also have copies of the relevant books describing the system software for Macintosh computers available in technical bookstores and on the World Wide Web at

<http://developer.apple.com/techpubs/mac/mac.html>

3D Graphics

Developers of 3D graphics for games should know about OpenGL for Macintosh®, a new version of SGI’s application programming interface (API) and software library for 3D graphics.

Information is available on the World Wide Web at

www.apple.com/opengl

Developer support and documentation is available at

<http://developer.apple.com/opengl/>

PowerPC G3 Microprocessor

For more information about the PowerPC 750™ microprocessor used in the iMac family of computers, developers may wish to refer to the standard reference, *PowerPC Arthur Microprocessor Implementation Definition Book IV*. Information about the PowerPC 750 and other G3 microprocessors is also available on the World Wide Web at

<http://www.mot.com/SPS/PowerPC/index.html>

<http://www.chips.ibm.com/products/powerpc/>

RAM Expansion Modules

The new Mac family of computers use PC-100 compliant 168-pin SDRAM DIMMs. The mechanical characteristics of the DIMM are given in the JEDEC specification for the 168-pin 8-byte DRAM DIMM. The specification number is JEDEC MO-161; the specification is available from the Electronics Industry Association's web site, at

<http://www.jedec.org/download/freestd/pub95/mo161C.pdf>

The electrical characteristics of the DIMM are given in section 4.5.6 of the JEDEC Standard 21-C, release 7. The specification is available from the Electronics Industry Association's web site, at

<http://www.jedec.org/download/freestd/pub21/>

The RAM DIMMs are required to be the PC-100 compliant. The PC-100 specification is available from Intel's web site, at

<http://developer.intel.com/design/chipsets/memory/sdram.htm#S1>

ATA Devices

For the latest information about the system software for ATA devices such as the hard drive, see *ATA Device Software for Macintosh Computers*. That book is available on the reference library issue of the developer CD (June, 1999) and on the world wide web at

http://developer.apple.com/techpubs/hardware/DeviceManagers/ata/ata_ref/frameset.html

The specification for Ultra DMA IDE interface used in the iMac family of computers is ANSI T13/1153D and is available from the Technical Committee T13 web site at

<http://www.t13.org/>

USB Interface

For more information about USB on the Macintosh computer, developers should refer to Apple Computer's *Mac OS USB DDK API Reference*. Information is also available on the World Wide Web, at:

<http://developer.apple.com/techpubs/hardware/DeviceManagers/usb/usb.html>

P R E F A C E

USB game controllers are supported by the InputSprocket component of the Apple Games Sprockets software architecture. InputSprocket software and information about the InputSprocket APIs can be found at

<http://developer.apple.com/games/>

For full specifications of the Universal Serial Bus, developers should refer to the USB Implementers Forum on the World Wide Web, at:

<http://www.usb.org/developers/index.html>

FireWire Interface

For additional information about the FireWire IEEE 1394 interface and the Apple APIs for FireWire software, refer to the resources available on the Apple FireWire web site at:

<http://www.apple.com/firewire/>

The IEEE 1394 standard is available from the IEEE. Ordering information can be found on the World Wide Web at

<http://www.ieee.org>

You may also find useful information at the 1394 Trade Association's web site:

<http://www.1394ta.org/>

Mac OS 8.6

For a description of the version of the Mac OS that comes with the new models, developers should refer to the technote for Mac OS 8.6. Other technotes contain information about the New World software architecture and the API changes for Power Manager 2.0 referred to in Chapter 5, "Software." The technotes are available on the Technote web site at

<http://developer.apple.com/technotes/>

Developers should also have copies of the relevant books describing the system software for Macintosh computers available in technical bookstores and on the World Wide Web at

<http://developer.apple.com/techpubs/mac/mac.html>

Open Firmware

Three Technotes provide an introduction to Open Firmware on the Macintosh platform. They are:

TN 1061: Open Firmware, Part I, available on the Technote web site at <http://developer.apple.com/technotes/tn/tn1061.html>

TN 1062: Open Firmware, Part II, available on the Technote web site at <http://developer.apple.com/technotes/tn/tn1062.html>

TN 1044: Open Firmware, Part III, available on the Technote web site at <http://developer.apple.com/technotes/tn/tn1044.html>

The New World software architecture referred to in Chapter 5, “Software,” follows some of the standards defined by the Open Firmware IEEE 1274-1995 specification and the CHRP binding.

The basis for the bootinfo file format and use is the document *PowerPC™ Microprocessor Common Hardware Reference Platform (CHRP™) System binding to IEEE Std 1275-1994 Standard for Boot (Initialization, Configuration) Firmware*. A bootinfo file contains Open Firmware script, a description, information for individual operating systems, icons, along with other information.

Other Open Firmware references of possible interest include:

IEEE 1275-1994 Standard for Boot (Initialization, Configuration) Firmware: Core Requirements and Practices

IEEE Std 1275-1994 Standard for Boot (Initialization, Configuration) Firmware (Version 1.7)

Open Firmware Recommended Practice: Device Support Extensions (Version 1.0)

Open Firmware Recommended Practice: Interrupt Mapping (Version 0.9)

P R E F A C E

Introduction

This chapter lists features of the all-new iMac family of computers, summarizes the changes the iMac has undergone since its introduction, and points out issues affecting compatibility.

Model History

Since its introduction in the summer of 1998, the iMac computer has been updated several times. Table 1-1 lists the features that have changed from model to model of the original iMac, the rev-B iMac, the five-color iMacs, and the new iMac family.

Table 1-1 Feature differences

	Original iMac	Rev-B iMac	5-color iMacs	new iMac family
CPU speed	233 MHz	233 MHz	266 MHz or 333 MHz	350 or 400 MHz
L2 cache speed	117 MHz	117 MHz	133 MHz	140 or 160 MHz
System bus speed	66 MHz	66 MHz	66 MHz	100 MHz
Main memory	32 MB up to 128 MB	32 MB up to 128 MB	32 MB up to 256 MB	64 or 128 MB up to 512 MB
Graphics IC	ATI RAGE IIC	ATI RAGE Pro	ATI RAGE Pro Turbo	ATI RAGE 128 VR
Graphics memory	2 MB, expandable	6 MB	6 MB	8 MB, AGP expansion
Hard disk drive	4 GB IDE	4 GB IDE	6 GB IDE	6, 10, or 13 GB IDE
CD drive	Tray-load CD-ROM	Tray-load CD-ROM	Tray-load CD-ROM	Slot-load CD-ROM or DVD-ROM

continued

Table 1-1 Feature differences (continued)

	Original iMac	Rev-B iMac	5-color iMacs	new iMac family
Data ports	USB	USB	USB	USB and optional FireWire
Communication features	56K modem; IR port	56K modem	56K modem	56K modem; optional AirPort card wireless LAN module
Sound features	Stereo and surround	Stereo and surround	Stereo and surround	Enhanced AC-3 and surround

Features

Here is a list of the features of the iMac family of computers. Each feature is described in more detail in a later chapter.

- **Processor:** The new iMac computers have a PowerPC G3 microprocessor running at a clock speed of 350 or 400 MHz. For more information, see “G3 Microprocessor” (page 26).
- **Cache:** The computers have a backside L2 cache consisting of 512 KB of fast static RAM. For more information, see “Backside Cache” (page 27).
- **Memory:** The computers come with 64 or 128 MB of SDRAM installed in one of two standard 168-pin DIMM expansion slots. For more information, see “RAM Expansion Modules” (page 54).
- **Hard disk storage:** The built-in hard disk drive has a capacity of 6, 10, or 13 GB. For more information, see “Hard Disk Drive” (page 44).
- **CD-ROM or DVD-ROM drive:** The new iMac computer has a built-in CD-ROM drive with 24X speed. The iMac DV models have a DVD-ROM with 4X speed. Both drives use slot loading of the media. For more information, see “CD-ROM Drive” (page 44) and “DVD-ROM Drive” (page 44).

- **Display:** The iMac family computers have a built-in 15-inch color monitor with a 13.8-inch viewable diagonal. For more information, see “Video Display” (page 45).
- **External video monitor:** The iMac DV models have a port for connecting an external video monitor. For more information, see “Video Monitor Port” (page 46).
- **Graphics acceleration:** The video circuits provide built-in 2D and 3D acceleration using an ATI RAGE 128 VR IC. For more information, see “Video Display Subsystem” (page 29).
- **Video RAM:** The video IC includes 8 MB of video SDRAM, which supports 3D features and millions of colors. For more information, see “Video Display Subsystem” (page 29).
- **USB ports:** The computer has two USB ports for keyboard, mouse, and other USB devices, described in “USB Ports” (page 34).
- **FireWire ports:** The iMac DV models have two IEEE-1394 high-speed serial FireWire ports, which support transfer rates of 100, 200, and 400 Mbps. For more information, see “FireWire Ports” (page 38).
- **Modem:** The iMac family computers have a built-in V.90 modem with a 56 Kbps data rate. For more information, see “Internal Modem” (page 41).
- **Ethernet:** The iMac family computers have a built in Ethernet port for a 10Base-T and 100Base-TX operation. For more information, see “Ethernet Port” (page 40).
- **AirPort Card slot:** An internal AirPort Card wireless LAN module is available as a build-to-order option or as a user-installable upgrade. For more information, see “AirPort Card Wireless LAN Module” (page 42).
- **Sound:** The iMac family computers have a built-in microphone and two stereo speakers, line-level stereo input and output jacks, and two stereo headphone jacks. The sound system includes playback of AC-3 surround sound from DVD video discs. For more information, see “Sound System” (page 49).
- **Keyboard and mouse:** The computers come with an Apple USB keyboard and Apple USB mouse. The keyboard is also a USB hub with two USB ports. For more information, see “Keyboard” (page 47) and “Mouse” (page 49).

- **Size and weight:** The new iMac computer is 39.5 cm (15.8 inches) high, 38.0 cm (15.2 inches) wide, and 44.0 cm (17.6 inches) deep; it weighs 15.5 kg (34.0 pounds).

External Features

The iMac family of computers are housed in two-tone plastic enclosures that include the display. The separate keyboard and mouse are also designed in two-tone plastic.

The top of the enclosure includes a built-in handle for carrying the computer. The handle can also be used to secure the computer using a cable and lock.

The bottom of the enclosure has a hinged support that can be used to change the tilt angle of the front of the computer from about 11 degrees to about 17 degrees.

The front of the enclosure is dominated by the 15-inch display. The front also includes, below the display, the following features:

- CD-ROM or DVD-ROM drive slot, in the center
- Stereo speakers, one on either side
- Two headphone jacks, next to the speaker on the left side
- Power button, green when on, pulsing amber in Sleep mode, located near the speaker on the right side

The receptacle for the power cord is located on the back. The connector for an external video monitor is located on the underside of the back.

The right side of the enclosure, as viewed from the front, contains the I/O panel. The I/O panel contains the following features:

- Sound input and output jacks
- Two FireWire ports (on some configurations)
- Modem connector
- Ethernet port
- Two USB ports
- Programmer's buttons: reset and NMI

The back portion of the bottom of the enclosure has a hinged plastic door that can be opened for access to the expansion RAM and the AirPort Card slot. For more information, see “RAM Expansion Slots” (page 54).

Compatibility Issues

While the iMac family of computers has many new features, there should be no compatibility problems with applications that operate correctly with other Macintosh models. Compatibility issues for expansion and peripheral devices are listed here.

Main RAM Expansion Modules

For expansion of main RAM, the iMac family computers use 168-pin DIMMs that contain SDRAM devices and are PC-100 compliant. For more information, see “RAM Expansion Modules” (page 54).

IMPORTANT

The 168-pin DIMMs used in the iMac family of computers are not the same as the 144-pin SO-DIMMs used in earlier iMac models. ▲

USB Ports and Devices

The USB ports take the place of the ADB and serial I/O ports found on previous Macintosh computers. Software shims are provided to allow existing applications designed to work with ADB mice and keyboards to work with the equivalent USB devices. See “ADB Legacy” (page 68).

For information about the cursor-control devices on the Macintosh computer, see Technote hw01, *ADB-The Untold Story: Space Aliens Ate My Mouse*, available on the World Wide Web at

http://developer.apple.com/technotes/hw/hw_01.html

USB game controllers are supported by the InputSprocket component of the Apple Games Sprockets software architecture. InputSprocket software and information about the InputSprocket APIs can be found at

CHAPTER 1

Introduction

<http://developer.apple.com/games/>

For more information about USB on the Macintosh computer, developers should refer to Apple Computer's *Mac OS USB DDK API Reference*. Information is also available on the World Wide Web, at:

<http://developer.apple.com/techpubs/hardware/DeviceManagers/usb/usb.html>

CHAPTER 1

Introduction

Architecture

This chapter describes the architecture of the iMac family of computers. It includes information about the major components on the main logic board: the microprocessor, the other main ICs, and the buses that connect them to each other and to the I/O interfaces.

Block Diagram and Buses

This section is an overview of the major ICs and buses on the computer's main logic board.

Block Diagram

Figure 2-1 is a simplified block diagram of the main logic board. The diagram shows the main ICs and the buses that connect them together.

Figure 2-1 Block diagram

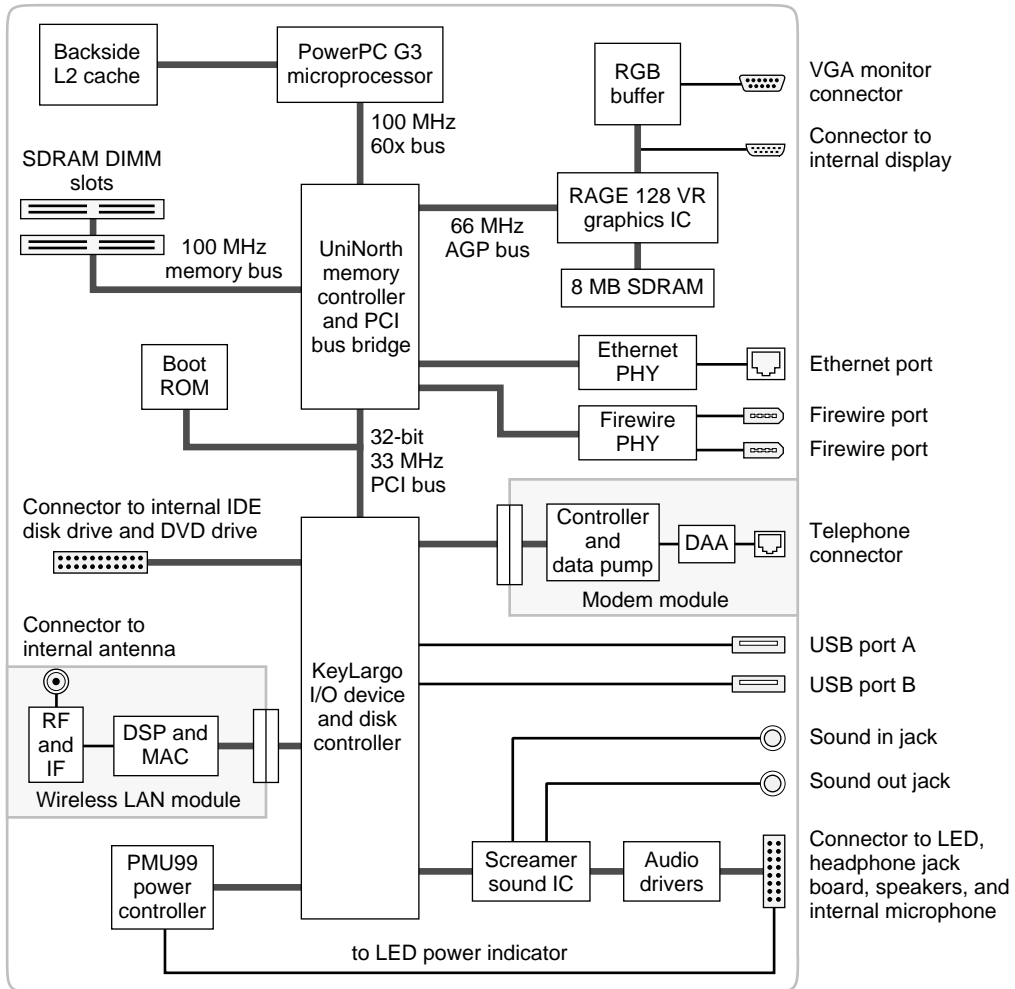

Main ICs and Buses

The architecture of the iMac family of computers is designed around the PowerPC G3 microprocessor and two new custom ICs: the Uni-N memory controller and bus bridge, and the KeyLargo I/O device controller. Those three ICs occupy the center of the block diagram.

The PowerPC G3 microprocessor is connected to the Uni-N memory controller and bus bridge IC by a 60x bus with 64 data lines and a bus clock speed of 100 MHz. The Uni-N IC has other buses that connect with the KeyLargo IC, the main system RAM, and the graphics IC. The buses implemented by the Uni-N IC are summarized in Table 2-1, which is in the section “Memory Controller and Bus Bridge”.

The Uni-N IC is connected to the KeyLargo I/O controller IC by a 32-bit PCI bus with a bus clock speed of 33 MHz. That bus also connects to the Boot ROM. The KeyLargo IC has other buses that connect with the hard disk drive and the CD-ROM or DVD-ROM drive, the power controller IC, the sound IC, the internal modem module, and the optional wireless LAN module.

Each of the components listed here is described in one of the following sections.

Microprocessor and Cache

The microprocessor communicates with the rest of the system by way of a 100-MHz, 64-bit 60x bus to the Uni-N IC. The microprocessor has a separate backside bus to its second-level cache.

G3 Microprocessor

The processor in the iMac family of computers is a PowerPC G3 microprocessor. The G3 microprocessor has several features that contribute to superior performance, including:

- large on-chip (L1) caches, 32 KB each for instruction cache and data cache
- a built-in cache controller and cache tag RAM for the second level (L2) cache
- a separate backside bus for the L2 cache, providing faster clock speed and overlapped bus transactions
- a microprocessor core optimized for Mac OS applications

The G3 microprocessor in the iMac family of computers runs at a clock speed of 350 or 400 MHz.

Backside Cache

The data storage for the backside L2 cache consists of 512 KB of fast static RAM on the main logic board. The controller and tag storage for the backside cache are built into the microprocessor. The cache controller includes bus management and control hardware that allows the cache to run at a sub-multiple of the processor's clock speed, rather than at the clock speed of the main system bus. The ratio of the clock speeds of the microprocessor and the backside cache is 5:2.

Memory Controller and Bus Bridge

The Uni-N memory controller and bus bridge IC provides cost and performance benefits by combining several functions into a single IC. It contains the memory controller, the PCI bus bridge, the Ethernet and FireWire interfaces, and the AGP port.

In addition to the four buses listed in Table 2-1, the Uni-N IC also has separate interfaces to the physical layer (PHY) ICs for Ethernet and FireWire and an I²C interface that is used for configuring the memory subsystem.

Table 2-1 Buses supported by the Uni-N IC

Name of bus	Destinations	Width of data path	Bus clock speed
60x bus	Microprocessor	64 bits	100 MHz
Memory bus	System RAM	64 bits	100 MHz
PCI bus	KeyLargo IC and Boot ROM	32 bits	33 MHz
AGP port	Graphics IC	32 bits	66 MHz

The microprocessor and the I/O controller IC are described in their own sections. The following sections describe the other subsystems that are connected to the Uni-N IC.

System RAM

The memory subsystem in the iMac family of computers supports two slots for 168-pin DIMMs (dual inline memory modules). One slot is occupied by a DIMM containing 64 MB of SDRAM; the second slot is an expansion slot. The data bus to the RAM and DIMM is 64 bits wide, and the memory interface is synchronized to the 60x bus interface at 100 MHz. See “RAM Expansion” (page 53).

Boot ROM

The boot ROM is connected to the Uni-N IC by way of the PCI bus plus three additional control signals: chip select, write enable, and output enable. The boot ROM is a 1 M by 8 bit device.

FireWire Controller

The Uni-N IC includes an IEEE 1394a FireWire controller with a maximum data rate of 400 Mbits (50MBytes) per second. The Uni-N IC provides DMA (direct memory access) support for the FireWire interface.

The controller IC implements the FireWire link layer. A physical layer IC, called a PHY, implements the electrical signalling protocol of the FireWire interface. The PHY supports two FireWire ports by way of external connectors in the I/O bay.

The computer is capable of accepting external power through the FireWire connector to operate the PHY when the computer is turned off. While the PHY is operating, it acts as a repeater from one port to another so that the FireWire network remains connected. For more information, see “FireWire Ports” (page 38).

Ethernet Controller

The Uni-N IC includes an ethernet media access controller (MAC) that implements the Link layer. As a separate channel connected directly to the

Uni-N IC, it can operate at its full capacity without degrading the performance of other peripheral devices. The Uni-N IC provides DB-DMA support for the Ethernet interface.

The controller is connected to a PHY interface IC that is capable of operating in either 10-BaseT or 100-BaseTX mode. The actual speed of the link is automatically negotiated by the PHY and the bridge or router to which it is connected. For more information, see “Ethernet Port” (page 40).

Video Display Subsystem

The display subsystem consists of a graphics controller ASIC and 8 MB of SDRAM on the main logic board. The graphics controller IC is an ATI RAGE 128 VR. It contains 2D and 3D acceleration engines, front-end and back-end scalars, a CRT controller, and an AGP bus interface with bus master capability.

The interface between the graphics IC and the rest of the system is an AGP (accelerated graphics port) bus on the Uni-N IC. To give the graphics IC fast access to system memory, the AGP bus has separate address and data lines and supports deeply pipelined read and write operations. The AGP bus has 32 data lines and a clock speed of 66 MHz.

The graphics IC uses a graphics address remapping table (GART) to translate AGP logical addresses into physical addresses. The graphics driver software can allocate memory in both the dedicated SDRAM and the main memory.

For information about the display and supported resolutions, see “Video Display” (page 45).

I/O Device Controller

The I/O controller IC in the iMac family of computers is a custom IC called KeyLargo. It is an integrated I/O controller and DMA engine for use in Power Macintosh computers with a PCI bus.

The KeyLargo IC provides the interface and control signals for the following devices:

- the internal hard drive
- the CD-ROM or DVD-ROM drive

- the USB ports
- the built-in modem
- the sound codec IC
- the power manager IC
- the optional wireless LAN module

DMA Support

The KeyLargo IC provides DB-DMA (descriptor-based direct memory access) support for the following I/O channels:

- Ultra DMA IDE interface to the the internal hard drive and the CD-ROM drive or DVD-ROM drive
- modem slot interface to the built-in modem
- DAV channel to the sound IC

The DBDMA system provides a scatter-gather process based on memory resident data structures that describe the data transfers. The DMA engine is enhanced to allow bursting of data files for improved performance.

Interrupt Support

The KeyLargo IC has an interrupt controller (MPIC) that handles interrupts generated within the IC as well as external interrupts, such as those from the Ethernet and FireWire controllers.

USB Interface

The KeyLargo IC implements two independent USB controllers (root hubs), each of which is connected to one of the ports on the back panel of the computer. The use of two independent controllers allows both USB ports to support high data rate devices at the same time with no degradation of their performance. If a user connects a high-speed (12 Mbps) device to one port and another high-speed device to the other, both devices can operate at their full data rates.

The two external USB connectors support USB devices with data transfer rates of 1.5 Mbps or 12 Mbps. For more information about the connectors, see “USB Ports” (page 34).

USB devices connected to the iMac family of computers are required to support USB-suspend mode as defined in the USB specification. Information about the operation of USB-suspend mode on Macintosh computers is included in the *Mac OS USB DDK API Reference*. That document is part of Apple’s USB DDK and is available on the World Wide Web, at:

<http://developer.apple.com/techpubs/hardware/DeviceManagers/usb/usb.html>

The USB ports on the iMac family of computers comply with the Universal Serial Bus Specification 1.1 Final Draft Revision. The USB controllers comply with the Open Host Controller Interface (OHCI) specification.

Ultra DMA Interface

In the iMac family of computers, the KeyLargo IC provides an Ultra DMA IDE (integrated drive electronics) channel that is connected to the internal hard disk drive and the CD-ROM or DVD-ROM drive. The KeyLargo IC provides DB-DMA (descriptor-based direct memory access) support for the Ultra DMA interface.

The Ultra DMA IDE interface, also called Ultra-DMA/33 and ATA-4, is an improved version of the EIDE interface.

The internal hard disk drive is connected as device 0 (master) in an ATA Device 0/1 configuration; the CD-ROM drive or DVD-ROM drive is an ATAPI drive and is connected as device 1 (slave).

Modem Support

The KeyLargo IC has a Macintosh serial port that is the interface to the modem connector. The KeyLargo IC provides DB-DMA support for the modem interface. The modem provides analog call progress signals to the Screamer sound IC.

The internal hardware modem is a separate module that contains the modem ICs (controller and datapump) and the interface to the telephone line (DAA). For more information about the modem, see “Internal Modem” (page 41).

Sound IC Support

The KeyLargo IC has a traditional DAV port that connects to the Screamer sound IC. The KeyLargo IC provides DB-DMA support for the DAV port.

The Screamer sound IC is an audio codec with added input and output controls. It is a 16-bit device with two analog stereo input channels and two analog stereo output channels. Either stereo pair of input channels can be selected for digitization by the internal A-to-D converter.

For a description of the features of the sound system, see “Sound System” (page 49).

Power Controller

The power management controller in the iMac family of computers is a custom IC called the PMU99. It supports several power-saving modes of operation, including idle, doze, and sleep. For more information, see “Power Saving Modes” (page 66).

Wireless LAN Module

The interface between the wireless LAN module and the KeyLargo IC is a subset of the PCMCIA interface.

The module contains a media access controller (MAC), a digital signal processor (DSP), and a radio-frequency (RF) section. The module has a connector for the cable to the antennas, which are built into the computer’s enclosure .

The wireless LAN module is based on the IEEE 802.11 standard. The wireless LAN module transmits and receives data at up to 11 Mbps and is compatible with older systems that operate at 1 or 2 Mbps. For information about its operation, see “AirPort Card Wireless LAN Module” (page 42).

Devices and Ports

This chapter describes both the built-in I/O devices and the ports for connecting external I/O devices. Each of the following sections describes an I/O port or device.

USB Ports

The iMac family computers have two Universal Serial Bus (USB) ports that are used for connecting the keyboard and mouse as well as additional I/O devices such as printers, scanners, and low-speed storage devices. The USB ports are connected to separate USB root hubs, allowing both USB ports to support 12 Mbps devices at the same time with no degradation of their performance. See “USB Interface” (page 30).

For more information about USB on Macintosh computers, please refer to Apple Computer’s *Mac OS USB DDK API Reference* and the other sources listed in “USB Interface” (page 11).

USB Connectors

The USB ports use USB Type A connectors, which have four pins each. Two of the pins are used for power and two for data. Figure 3-1 is an illustration of a Type A port; Table 3-1 shows the pin assignments.

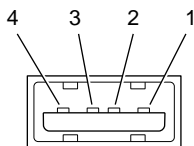
Figure 3-1 USB Type A port and pins**Table 3-1** Pin assignments on the USB port

Pin	Signal name	Description
1	VCC	+5 VDC
2	D-	Data -
3	D+	Data +
4	GND	Ground

The iMac family computers provide 5-volt power to the USB ports. The maximum total current available is 500 mA on each port.

The USB ports support both low-speed and high-speed data transfers, at up to 1.5 Mbits per second and 12 Mbits per second, respectively. High-speed operation requires the use of shielded cables.

The iMac family computers come with version 1.3 of the Macintosh USB system software, which supports all four data transfer types defined in the USB specification.

USB Features

Features of the USB ports include power saving modes and the ability to start up the computer from an USB mass-storage device.

Power Off During Sleep

In the iMac family of computers, the USB port can be completely powered down during Sleep mode. USB devices must be able to start up again when the computer wakes up from Sleep mode. This functionality is part of the

USB-suspend mode defined in the USB specification. Information about the operation of USB-suspend mode on Macintosh computers is included in the *Mac OS USB DDK API Reference*, available on the World Wide Web at

<http://developer.apple.com/techpubs/hardware/DeviceManagers/usb/usb.html>

In addition to restarting themselves out of Sleep mode, USB devices can also provide a remote wakeup function for the computer. The USB root hub in the computer is set to support remote wakeup whenever a device is attached to or disconnected from the bus. The mouse and keyboard that come with the computer use this method to wake the computer on a key press or mouse motion.

Connect and Resume

The KeyLargo IC contains special circuitry that allows the computer to wake from Sleep mode on connect, disconnect, and resume events. Compatible USB devices should support the USB-suspend mode defined in the USB specification.

USB Storage Devices

The iMac family computers can boot from a USB storage device that follows the USB Mass Storage Class specification.

Class drivers are software components that are able to communicate with many USB devices of a particular kind. If the appropriate class driver is present, any number of compliant devices can be plugged in and start working immediately without the need to install additional software. The Mac OS for the iMac family of computers includes USB Mass Storage Support 2.0, a class driver that supports devices that meet the USB Mass Storage Class specification.

USB Controller

The iMac family computers use an Open Host Controller Interface (OHCI) controller for USB communication. Some early USB devices (most notably keyboards) can't interoperate with an OHCI controller. Those devices are not supported by the Macintosh USB system software.

USB Compatibility Issues

The USB ports take the place of the ADB and serial I/O ports found on earlier Macintosh computers, but they do not function the same way. The following sections describe the differences.

ADB Compatibility

Apple is providing an ADB/USB shim to support processes that control ADB devices by making calls to the ADB Manager and the Cursor Device Manager. The ADB/USB shim makes it possible for processes that support an ADB keyboard to work with the USB keyboard equivalent.

For example, the ADB/USB shim allows applications to set the caps lock and num lock LEDs on the Apple USB keyboard. The ADB/USB shim also allows the Cursor Device Manager to support a USB mouse.

Keyboards other than the Apple USB keyboard can be used with the iMac family of computers, but they will be treated as having an ADB device ID of 2.

IMPORTANT

The ADB/USB shim does not support other types of ADB devices. ▲

Note

The ADB/USB shim is built into the Mac OS ROM image on the iMac family of computers, as it is on all Power Macintosh systems that have USB ports. For more information about the Mac OS ROM image, refer to Chapter 5, “Software.” ◆

Serial Port Compatibility

Mac OS 8.6 includes a Serial shim, called SerialShimLib, that enables processes that use the Communications Toolbox CRM to find and use a USB device. For more information about the shim, and a sample modem driver that shows how to use it, please refer to the Mac OS USB DDK, available from the Apple Developer Development Kits page on the World Wide Web, at

<http://developer.apple.com/sdk/>

Apple also provides a USB Communication Class driver, so modem vendors whose devices comply with the USB Communication Class specification do not

need to write their own vendor-specific USB class drivers. See “USB Drivers” (page 67).

Not for Networking

USB is a serial communications channel, but it does not replace LocalTalk functionality on Macintosh computers; you cannot connect two Macintosh computers together using the USB. The best method for networking iMac computers is through the built-in Ethernet port.

FireWire Ports

The iMac DV models include two external FireWire IEEE 1394 ports. The features of the FireWire ports are:

- Support serial I/O at 100, 200, and 400 Mbps (megabits per second)
- Share up to 6 watts of power when the computer system is on
- Accept external power input from the bus

The FireWire hardware and software provided with the iMac family computers are capable of all asynchronous and isochronous transfers defined by IEEE standard 1394.

Developers of FireWire peripherals are required to provide device drivers. A driver for DV (digital video) is included in QuickTime 4.0.

It is possible to connect two computers to each other using a FireWire cable, but no software is provided to make use of such a connection.

FireWire Connector

The FireWire connector has six contacts, as shown in Figure 3-2. The connector pin assignments are shown in Table 3-2.

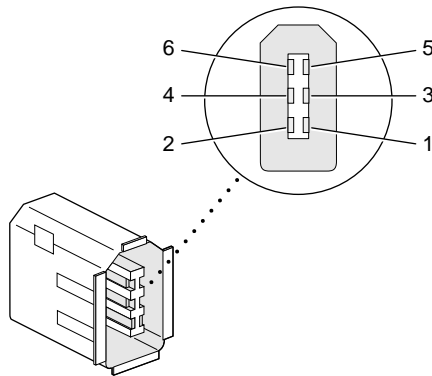
Figure 3-2 FireWire connector**Table 3-2** Pin assignments on the FireWire connector

Pin	Signal name	Description
1	Power	unregulated DC; 18-24 V no load
2	Ground	Ground return for power and inner cable shield
3	TPB-	Twisted-pair B, differential signals
4	TPB+	Twisted-pair B, differential signals
5	TPA-	Twisted-pair A, differential signals
6	TPA+	Twisted-pair A, differential signals
Shell	—	Outer cable shield

When the computer is on, the power pin provides a maximum voltage of 24 V (no load) and up to 6 W total power (shared by both connectors). Maximum current is 0.5 A and is controlled by an auto-resetting fuse.

The power pin also accepts external power at 8 to 33 V, in conformity with the P1394a draft standard, to keep the FireWire bus connected when the computer is turned off.

Voltage—up to 15 V—is still present at the power pin when the computer is in Sleep mode or when it is off but the power cord is still plugged in, and devices that use less than 1 W can continue to operate.

▲ **WARNING**

Devices that draw several watts of power from pin 1 should not attempt to operate while the computer is in Sleep mode or is turned off. Doing so is likely to exceed the 0.5 A maximum current and blow the fuse. ▲

Pin 2 of the 6-pin FireWire connector is ground for both power and inner cable shield. If a 4-pin connector is used on the other end of the FireWire cable, its shell should be connected to the wire from pin 2.

The signal pairs are crossed in the cable itself so that pins 5 and 6 at one end of the cable connect with pins 3 and 4 at the other end. When transmitting, pins 3 and 4 carry data and pins 5 and 6 carry clock; when receiving, the reverse is true.

For additional information about the FireWire interface and the Apple APIs for FireWire device control, developers should refer to the resources available on the Apple FireWire web site at:

<http://devworld.apple.com/dev/FireWire/index.html>

or send electronic mail to:

firewire@apple.com

Ethernet Port

The iMac family computers have a built-in 10/100 Mbps Ethernet port. The user can connect it to either a 10Base-T or a 100Base-TX hub; the port will automatically sense which type of hub is connected.

The connector for the Ethernet port is an RJ-45 connector located on the I/O panel. Table 3-3 shows the signals and pins on the connector.

Table 3-3 Signals on the Ethernet connector

Pin	Signal name	Signal definition
1	TXP	Transmit (positive lead)
2	TXN	Transmit (negative lead)
3	RXP	Receive (positive lead)
4	–	Not used
5	–	Not used
6	RXN	Receive (negative lead)
7	–	Not used
8	–	Not used

The Ethernet interface in the iMac computers conforms to the ISO/IEC 802.3 specification, where applicable.

Internal Modem

The iMac family computers come with a built-in modem. The telephone connector for the modem is an RJ-11 connector on the I/O panel.

The modem has the following features:

- modem bit rates up to 56 Kbps (supports V.90 and K56flex modem standards)
- Group 3 fax modem bit rates up to 14.4 Kbps

The modem appears to the system as a serial port that responds to the typical AT commands. The modem provides an analog sound output for monitoring the progress of the modem connection.

AirPort Card Wireless LAN Module

The iMac family computers support the AirPort Card, an internal wireless LAN module. The AirPort Card is available as a build-to-order option or as a user-installable upgrade.

The AirPort Card can be used for local printer sharing, file exchange, internet access, and email access.

The AirPort Card transmits and receives data at up to 11 Mbps. It is also interoperable with some older wireless LANs, as specified in “Hardware Components”.

Wireless connection to the internet or a wired LAN requires a base station as the connection to the internet or a bridge between the wireless signals and a wired LAN. Software included with the AirPort Card enables a Macintosh computer that has an AirPort Card installed to act as a base station. The user also has the option of purchasing an AirPort Base Station that can be connected to the wired LAN or to a 56k hardware modem.

Data Security

Three features of the AirPort Card help to maintain the security of data transmissions.

- The AirPort Card uses direct-sequence spread-spectrum (DSSS) technology that uses a multi-bit spreading code that effectively scrambles the data for any receiver that lacks the corresponding code.
- The AirPort Card software can use a table of authentic network client ID values to verify each client’s identity before granting access to the network.
- When communicating with a base station, the AirPort Card software encrypts the data using Wired Equivalent Privacy (WEP) with a 40-bit security key.

Hardware Components

The AirPort Card is a wireless LAN module based on the IEEE 802.11 standard and using direct-sequence spread-spectrum (DSSS) technology. It is

interoperable with PC-compatible wireless LANs that conform to the 802.11 standard and use DSSS.

The card contains a media access controller (MAC), a digital signal processor (DSP), and a radio-frequency (RF) section. The antennas are built into the computer's case.

The MAC provides the data communication protocols and the controls for the physical layer.

The DSP provides the core physical layer functionality and controls the RF section. The DSP communicates with the MAC for data exchange, physical layer control, and parameter settings.

The RF section provides modulation and transmission of outgoing signals and reception and demodulation of incoming signals. Its power output when transmitting is nominally 31 mW.

When transmitting data, the DSP converts the outgoing data stream into a direct-sequence spread-spectrum (DSSS) signal and sends it to the RF section. When receiving data, the DSP accepts incoming DSSS data from the RF section and converts it to a normal data stream.

Two antennas are connected to the AirPort Card. One antenna is always used for transmitting. Either of the two antennas may be used for receiving. Using a diversity technique, the DSP selects the antenna that gives the best reception.

Software Components

Software that is provided with the AirPort Card includes

- AirPort Setup Assistant, a standalone assistant that takes users through the steps necessary to set up the AirPort Card, set up an AirPort Base Station, or set up a software base station.
- AirPort Application, an application that allows users to switch between wireless networks and to create and join peer-to-peer networks.
- AirPort Control Strip Module, which provides a signal strength indication and most of the functions of the AirPort Application.
- AirPort Utility, a utility for the advanced user. With it the user can edit the administrative and advanced settings for a hardware or software base station. It can also be used to determine the location for the base station that gives the best reception.

Hard Disk Drive

The internal hard disk drive has a storage capacity of 6, 10, or 13 GB. The drive uses the Ultra DMA IDE interface, which is also referred to as the ATA-4 interface. The internal hard disk drive is connected as device 0 (master) in an ATA Device 0/1 configuration.

The software that supports the internal hard disk is the same as that in previous Macintosh models with internal IDE drives and includes DMA support. To obtain information about that software and about the ANSI standard for the Ultra DMA IDE interface, see “ATA Devices” (page 11).

CD-ROM Drive

The new iMac model has a 24X-speed internal CD-ROM drive. The CD-ROM drive supports the worldwide standards and specifications for CD-ROM and CD-digital audio discs described in the Sony/Philips Yellow Book and Red Book. The drive can read CD-ROM, CD-ROM XA, CD-I, and PhotoCD discs as well as play standard audio discs.

The CD-ROM drive uses slot loading of the disc. The drive features a mechanism that supports 4X, 8X, 12X, and 24X data transfer rates and a data buffer that further enhances performance.

Digital audio signals from the CD-ROM drive can be played through the sound outputs under the control of the Sound Manager.

The CD-ROM drive is an ATAPI drive and is connected as device 1 (slave) in an ATA Device 0/1 configuration.

DVD-ROM Drive

The iMac DV models have a 4X-speed internal DVD-ROM drive. The drive is fully compatible with existing CD-ROM media; it supports CD-ROM at 24X

speed maximum and DVD at 4X constant linear velocity (CLV). The DVD-ROM drive supports the following disc formats:

- DVD-ROM (one- or two-layer, one- or two-sided)
- DVD-RAM (read only)
- CD-ROM (Modes 1 and 2) and CD-ROM XA (Mode 2, Forms 1 and 2)
- CD-Audio, Photo CD, CD-RW (read only), CD-R (read only), and CD-Extra
- CD-I (Mode 2, Forms 1 and 2), CD-I Ready, and CD-I Bridge
- Video CD

Digital audio signals from the DVD-ROM can be played through the sound outputs under the control of the Sound Manager.

The DVD-ROM drive is an ATAPI drive and is connected as device 1 (slave) in an ATA Device 0/1 configuration.

Video Display

The built-in video display uses a 15-inch CRT (13.8-inch viewable diagonal). The CRT uses shadow-mask technology and has a dot pitch of 0.28 mm. The display has a fixed horizontal scan rate (60.015 kHz) and supports three resolutions. Table 3-4 lists the resolutions and the vertical scan rates supported. The display supports pixel depths up to 32 bits (millions of colors) at all resolutions.

Table 3-4 Display resolutions and pixel depths

Resolution	Vertical rate	Pixel depth
640 by 480	117.233 Hz	32 bits
800 by 600	94.97 Hz	32 bits
1024 by 768	75.03 Hz	32 bits

Video Monitor Port

The iMac DV models have a port for an external video monitor. The external monitor shows the same information as the built-in display, a mode sometimes called hardware video mirroring. The external monitor supports only the display sizes that are available on the internal monitor.

Monitor Connector

The connector for the analog video monitor is a three-row DB15 connector (DB9/15, also called mini sub D15) for use with a VGA, SVGA, or XGA monitor. Figure 3-3 shows the pin configuration and Table 3-5 lists the signal pin assignments.

Figure 3-3 Video connector

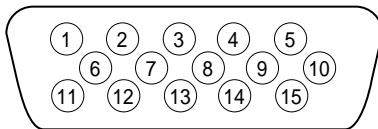

Table 3-5 Signals on the video connector

Pin	Signal name	Description
1	RED	Red video signal
2	GREEN	Green video signal
3	BLUE	Blue video signal
4	n.c.	No connect
5	GND	Ground
6	RED_RTN	Red video signal return
7	GREEN_RTN	Green video signal return

Table 3-5 Signals on the video connector (continued)

Pin	Signal name	Description
8	BLUE_RTN	Blue video signal return
9	n.c.	No connect
10	GND	Ground
11	n.c.	No connect
12	SDA	I ² C data
13	HSYNC	Horizontal synchronization signal
14	VSYNC	Vertical synchronization signal
15	SCL	I ² C clock

The connector on the monitor cable must fit into an opening in the computer's enclosure. The maximum dimensions of the connector's overmold are 34.81 mm (1.370 inches) wide and 15.40 mm (0.606 inches) high; no additional tolerance is allowed. The dimensions are symmetrical about the mounting screws; in other words, the horizontal and vertical center lines of the overmolding coincide with the center lines of the mounting screws.

Keyboard

The Apple USB keyboard has a total of 82 keys, including 12 function keys, a numeric keypad and a set of 4 cursor-control keys. The cursor-control keys are in the inverted-T arrangement.

Keyboard Layout

There are versions of the Apple USB keyboard with different key layouts for three standards used in different parts of the world: ANSI (US and North America), JIS (Japan), and ISO (Europe). Figure 3-4 shows the keyboard layout for the ANSI keyboard. Applications can determine which keyboard is connected by calling the Gestalt Manager and checking for the corresponding value of the `gestaltKeyboardType` selector:

- `gestaltUSBCosmoANSIKbd` (value = 198)
- `gestaltUSBCosmoJISKbd` (value = 200)
- `gestaltUSBCosmoISOKbd` (value = 199)

Figure 3-4 ANSI keyboard layout



Keyboard and USB

The Apple USB keyboard is designed to work with the iMac family of computers by way of the USB ports. The keyboard has a captive cable with a USB Type A connector. The keyboard is a bus-powered USB hub with two USB Type A ports.

▲ WARNING

A bus-powered hub does not provide enough power to support a second bus-powered hub. To use a second bus-powered hub with an iMac computer, connect it to the second USB port on the computer, not to a port on the Apple USB keyboard. ▲

Power to the computer can be turned on using the keyboard power button. A proprietary circuit allows the power control circuitry on the main logic board to detect a power-button press and turn on the power.

The standard NMI and reset key combinations are available, but the keys are decoded in software and may not be available under some crashed conditions. Therefore, NMI and reset switches are also available in the computer's I/O panel.

Apple provides a HID class driver for the Apple USB keyboard, which supports the USB boot protocol. Other keyboards intended for use on the Macintosh platform must support the HID boot protocol, as defined in the USB Device Class Definition for Human Interface Devices (HIDs).

Mouse

The iMac family computers come with an Apple USB mouse. The mouse case is round and has a two-tone color design to match the computer.

The mechanism inside the Apple USB mouse is similar to that in the Apple Desktop Bus Mouse II. The mouse ball is removeable for cleaning; the ring that allows access to the ball can be locked by inserting an unfolded paper clip into a small hole and turning the ring clockwise.

Sound System

The 16-bit stereo audio circuitry provides high-quality sound input and output through the built-in microphone and speakers. The user can also connect external input and output devices by way of the sound input and output jacks .

Note

The iMac family computers also support speakers and microphones that connect to the USB port.

The sound system is based on the Screamer codec IC and an output amplifier. The sound system supports sample sizes up to 16 bits at a sample rate of 44.1 kHz.

Sound Inputs

The sound system accepts inputs from five possible sources:

- built-in microphone
- external stereo sound input jack
- sound from internal CD or DVD player

- call progress audio from the internal modem
- sound from USB audio devices

Built-in Microphone

The sound signal from the built-in microphone is sent directly to the codec circuits in the Screamer IC.

External Sound Input Jack

The external sound input jack is a 3.5-mm mini phone jack located on the I/O panel on the right side of the computer. The sound input jack accepts line-level stereo signals or an Apple PlainTalk microphone. It also accepts a stereo miniplug-to-RCA cable adapter for connecting stereo equipment to the computer.

The sound input jack has the following electrical characteristics:

- input impedance: nominal 2000 ohms
- maximum level: nominal 1 V rms (2.8 V peak-to-peak)

Sound Outputs

The sound system sends computer-generated sounds to the built-in speakers, the sound output jack, and the headphone jacks.

The sound system provides user-selectable enhanced sound. The enhancements include

- enhancement of stereo sound sources for wider stereo
- using sound sprockets for simulation of immersive, interactive sonic environments, including sound objects that move in real time

Internal Speakers

The computer has two internal speakers. The computer turns off the sound signals to the internal speakers under the following conditions:

- when headphones are plugged into either headphone jack
- when a plug is inserted into the sound output jack

- when external USB speakers are connected
- during Sleep mode

External Sound Output

The external sound output jack is a 3.5-mm mini phone jack located on the I/O panel on the right side of the computer. It accepts a stereo miniplug-to-RCA cable adapter for connecting stereo equipment to the computer.

The sound output jack has the following electrical characteristics:

- output impedance: nominal 68 ohms
- maximum level: nominal 1 V rms (2.8 V peak-to-peak)

Headphone Jacks

Two headphone jacks are located on the front of the computer next to the left speaker. Each sound output jack provides enough current to drive a pair of low-impedance headphones.

The headphone jacks have the following electrical characteristics:

- output impedance: nominal 68 ohms
- maximum level: 1.0 V rms (2.8 V peak-to-peak)

Headphones should have an impedance not lower than the recommended minimum impedance of 32 ohms. Headphones with lower impedance can be used, but with some degradation in performance.

Sound Specifications

The frequency response of the sound circuits, not including the microphone and speakers, is within plus or minus 1 dB from 20 Hz to 20 kHz.

Total harmonic distortion plus noise (THD+N) as a percentage of full scale are shown in Table 3-6.

Table 3-6 Distortion specifications

Connector and level	Total harmonic distortion and noise
Line input	0.03%
Line output	0.03%
Headphone jack, open circuit	0.03%
Headphone jack, 32-ohm headphones, -20 dBFS level	0.1%
Headphone jack, 32-ohm headphones, -3 dBFS level	1.0%

The signal-to-noise ratios (SNR) for various inputs and outputs are shown in Table 3-7. The values shown are unweighted; values with A weighting would be about 8 dB higher.

Table 3-7 SNR specifications

Connector	Signal-to-noise ratio
Line output	85 dB
Headphone jacks	85 dB
Line input	85 dB
Internal CD or DVD, as analog sound source	85 dB
Internal CD or DVD, as digital sound source	96 dB

RAM Expansion

This chapter tells how to gain access to the expansion slots in the iMac family of computers and describes the RAM expansion modules.

RAM Expansion Slots

The new iMac-family computers have two RAM expansion slots. The slots accept standard PC-100 168-pin DIMMs (dual inline memory modules) using SDRAM devices. A DIMM for an iMac-family computer can contain either 64, 128, or 256 MB of memory.

IMPORTANT

The 168-pin DIMMs used in the iMac family of computers are not the same as the 144-pin SO-DIMMs used in earlier iMac models. ▲

A door on the bottom of the computer provides access to the RAM expansion slots. Before opening the bottom door, the user should place the computer face down on a soft cloth.

When the door is open, the portion of the main logic board that contains the two RAM expansion slots is visible. One slot is normally occupied by the factory-installed RAM DIMM. The other RAM expansion slot is available for a user-installed DIMM.

IMPORTANT

The user should be reminded to observe the usual precautions to avoid damage to the electronic components due to static electricity. ▲

RAM Expansion Modules

The RAM expansion modules for the iMac family computers are 168-pin SDRAM DIMMs that are 3.3 volt, unbuffered, 8-byte, non-parity, and PC-100 compliant. The speed of the SDRAM devices must be rated at 125 MHz (8 ns) or faster.

IMPORTANT

RAM expansion DIMMs for the iMac family of computers must be PC-100 compliant and use SDRAM devices. If the user installs a DIMM that uses EDO or SGRAM devices, the computer will beep several times when the user attempts to restart the computer. ▲

Mechanical Design of RAM DIMMs

The mechanical characteristics of the RAM expansion DIMM are given in the JEDEC specification for the 168-pin 8-byte DRAM DIMM. The specification number is JEDEC MO-161-D; the specification is available from the Electronics Industry Association's web site, at

<http://www.jedec.org/download/freestd/pub95/mo-161d.pdf>

The maximum height of DIMMs for use in the iMac family of computers is 1.50 inches.

Electrical Design of RAM DIMMs

The electrical characteristics of the RAM DIMM are given in section 4.5.6 of the JEDEC Standard 21-C. The specification is available from the Electronics Industry Association's web site, at

<http://www.jedec.org/download/freestd/pub21/>

The specification defines several attributes of the DIMM, including storage capacity and configuration, connector pin assignments, and electrical loading.

The presence detect serial EEPROM specified in the JEDEC standard is required and must be set to properly define the DIMM configuration. Details about the required values to be stored in the presence detect EEPROM can be found in sections 4.5.4 and 4.1.2.5 of the JEDEC standard 21-C specification.

The RAM DIMMs are required to be the PC-100 compliant. The PC-100 specification is available from Intel's web site, at

<http://developer.intel.com/design/chipsets/memory/sdram.htm#S1>

The SDRAM devices used in the RAM expansion modules must be self-refresh type devices for operation from a 3.3-V power supply. The speed of the SDRAM devices must be 125 MHz or greater, corresponding to a cycle time of 8 ns or less, as required by the PC-100 specification.

DIMM Configurations

The largest DIMM supported is a two-bank DIMM of 256 MB using 128 Mbit SDRAM devices. The minimum bank size supported by the memory controller is 2 MB, and the largest is 256 MB. The maximum number of devices per DIMM is 16.

Table 4-1 shows information about the different sizes of SDRAM devices used in the memory modules. The memory controller supports 64 Mbit and 128 Mbit SDRAM devices. The device configurations include three specifications: address range, word size, and number of banks. For example, a 1 M by 16 by 4 device addresses 1 M, stores 16 bits at a time, and has 4 banks.

The third column in Table 4-1 specifies the number of devices needed to make up the 8-byte width of the data bus. The fourth column in the table shows the size of each bank of devices, which is based on the number of internal banks in each device and the number of devices per bank. The last column shows the memory size of the largest DIMM with that device size that the computer can accommodate.

Table 4-1 Sizes of RAM expansion devices and modules

SDRAM device size	Device configuration	Devices per bank	Size of each bank	Size of DIMM
64 Mbits	4 M x 8 x 2	8	64 MB	128 MB
64 Mbits	2 M x 8 x 4	8	64 MB	128 MB
64 Mbits	2 M x 16 x 2	4	32 MB	128 MB
64 Mbits	1 M x 16 x 4	4	32 MB	128 MB
64 Mbits	1 M x 32 x 2	2	16 MB	128 MB
64 Mbits	512 K x 32 x 4	2	16 MB	128 MB
128 Mbits	8 M x 8 x 2	8	128 MB	256 MB
128 Mbits	4 M x 8 x 4	8	128 MB	256 MB
128 Mbits	4 M x 16 x 2	4	64 MB	256 MB

Table 4-1 Sizes of RAM expansion devices and modules (continued)

128 Mbits	2 M x 16 x 4	4	64 MB	256 MB
128 Mbits	2 M x 32 x 2	2	32 MB	256 MB
128 Mbits	1 M x 32 x 4	2	32 MB	256 MB

The iMac family computers accept either one or two DIMMs. Any of the supported DIMM sizes can be installed in either slot. The memory controller configures the combined memory of the DIMMs into a contiguous array of memory addresses.

Note

The iMac family computers do not support memory interleaving, so installing two DIMMs of the same size does not result in any performance gain.

RAM Addressing

Signals A[0] – A[12] and BA[0] – BA[1] on each RAM DIMM make up a 15-bit multiplexed address bus that can support several different types of SDRAM devices. Table 4-2 lists the types of devices that can be used in the iMac family of computers by size, configuration, and sizes of row and column addresses.

IMPORTANT

The iMac family of computers support only the types of SDRAM devices listed in Table 4-2. Other types of DRAM devices should not be used with these computers. ▲

Table 4-2 Address multiplexing modes for SDRAM DIMMs

Device size	Device configuration	Size of row address	Size of column address
64 Mbits	4 M x 8 x 2	13	9
64 Mbits	2 M x 8 x 4	12	9
64 Mbits	2 M x 16 x 2	13	8
64 Mbits	2 M x 16 x 2	11	10

Table 4-2 Address multiplexing modes for SDRAM DIMMs (continued)

Device size	Device configuration	Size of row address	Size of column address
64 Mbits	1 M x 16 x 4	12	8
64 Mbits	1 M x 32 x 2	11	9
64 Mbits	512 K x 32 x 4	11	8
128 Mbits	8 M x 8 x 2	13	10
128 Mbits	4 M x 8 x 4	12	10
128 Mbits	4 M x 16 x 2	13	9
128 Mbits	2 M x 16 x 4	12	9
128 Mbits	2 M x 32 x 2	13	8
128 Mbits	1 M x 32 x 4	12	8

Software

This chapter summarizes the ROM-in-RAM design of the software and describes the changes that have been made to support the iMac family of computers. Additional information about the ROM-in-RAM design, also called the New World architecture, is available in a technote at

<http://developer.apple.com/technotes/tn/tn1167.html>

The version of the Mac OS that comes with the iMac family of computers is Mac OS 8.6.

ROM in RAM

The system software in the new iMac family of computers uses the ROM-in-RAM approach first used in the original iMac computer. With this approach, a small ROM contains the code needed to initialize the hardware and load an operating system. The rest of the system code that formerly resided in the Mac OS ROM is loaded into RAM from disk or from the network.

The small ROM that is needed for the computer's start-up activities, called the boot ROM, is only 1 MB in size. It includes the hardware specific code and tables needed to start up the computer, to run Open Firmware, to provide common hardware access services, and to load the Mac OS ROM image.

High level software resides in an image called the Mac OS ROM that is read into RAM before the Mac OS begins operation. Once the Mac OS begins operation, the Mac OS ROM image in RAM behaves in the same way that the corresponding code in ROM formerly did. Most of the changes are completely transparent to the Mac OS.

Aspects of the New Approach

Some aspects of the ROM-in-RAM approach are apparent in the operation of the system.

RAM Footprint

The iMac computers have their Mac OS ROM image stored in RAM. The area of RAM that contains the Mac OS ROM image is excluded from the available memory space and is marked as read-only. This removes approximately 3

megabytes of RAM from availability for other uses. In effect, a system with 64 megabytes of RAM appears to have only 61 megabytes available.

Startup Disk Control Panel

Setting the startup device from the Startup Disk control panel makes the changes to the boot process that are needed for the ROM-in-RAM approach. The Startup Disk control panel sets the Open Firmware's boot-device configuration variable by modifying the Open Firmware NV-RAM partition that contains the Open Firmware's configuration variables.

IMPORTANT

The previous API for controlling the startup device selection, using `_GetDefaultStartup` and `_SetDefaultStartup`, is not effective on computers that use the ROM-in-RAM approach. ▲

Data Structures and Files

The Mac OS ROM image is contained in a new file, named “Mac OS ROM”, that is kept in the System Folder. The Mac OS ROM image is the same as it would be if it were an actual Mac OS ROM, containing the high-level software, the kernel software, and the 68K emulator.

Memory Mapping

With the ROM-in-RAM approach, memory is not mapped one-to-one as it has been for previous PCI-based Macs. This could be a compatibility issue with some software. Software that assumes the logical and physical addresses are the same will fail, even when virtual memory is not on. Well-behaved software—that is, software that always calls the `LogicalToPhysical` or `PrepareMemoryForIO` functions when it needs a physical memory address—will continue to work.

IMPORTANT

Designers of DMA device drivers should refer to *Designing PCI Cards and Drivers for Power Macintosh Computers* for information about using the `PrepareMemoryForIO` function to set up mapping for physical and logical addresses. The relevant section is on pages 219–229. For device drivers running with the NewWorld software, the sentence on page 227 that says “Certain DMA transactions require both mapping tables” should be interpreted to mean “All DMA transactions require both mapping tables.”

Boot Process

The boot process for the iMac family of computers is similar to that for other Macintosh computers that use the ROM-in-RAM approach. The PowerPC processor executes its reset vector as defined by the Hardware Initialization code. This code runs diagnostics tests, and when enough hardware initialization has been performed to run Open Firmware, the boot beep sound is played and Open Firmware begins executing. The Open Firmware module probes the system’s I/O buses to determine the device configuration and builds a device tree describing the hardware it finds.

The boot device, selected by the user with the Startup Disk control panel, is stored in Open Firmware’s NVRAM. Open Firmware attempts to locate that boot device, which can be a hard disk, a CD, a USB storage device, or a network connection. If the selected boot device is not found, Open Firmware searches for a suitable boot device according to a predetermined search order.

Once the boot device has been found, the Mac OS ROM image is loaded into memory, decompressed, and write-protected so that it behaves just like a ROM.

The user may interrupt Open Firmware’s boot device selection by holding down the option key while booting. This invokes the OS Picker, an Open Firmware application that lets the user select an alternate operating system or boot device. The default OS is the Mac OS ROM image, loaded from the current startup device.

Some of the Mac OS ROM boot code is written in 68K code. In order to run the 68K ROM, the PowerPC Nanokernel is loaded, and the emulator task is started. The emulator begins executing code in the 68K ROM. This code uses the device tree provided by Open Firmware to install device drivers, Macintosh OS

Services (referred to as Toolbox Managers), and finally the ROM loads the rest of the operating system from the startup device.

Boot ROM Contents

The boot ROM image in the iMac family of computers serves as the container for the CPU specific software required for loading the Mac OS.

Hardware Initialization Code

The hardware initialization portion of the boot ROM contains calls to a series of Power-On Self Test (POST) routines. The principle features are a ROM checksum test, memory testing, detection of the manufacturing test pin, and test manager support. These diagnostics run in native Power PC code.

The hardware initialization code on the new iMac family computers is different from that on earlier iMac models because of the new ICs (Uni-N and KeyLargo). Additional diagnostics are run out of the ROM in emulation.

Functions of the hardware initialization code include

- Initialization of the Uni-N bridge and memory controller IC
- Memory sizing using I²C presence detect on the memory module
- Memory timing setup with support for fast SDRAM devices
- L2 cache detection and sizing
- Initialization of the KeyLargo I/O controller IC
- Generating diagnostic sounds, including the boot chord that is emitted when hardware initialization has been successfully completed

The firmware in the boot ROM sets up and sizes memory, then stores the information in the device tree where it is available to the OS. The firmware obtains information about the memory by way of the Serial Presence Detect mechanism of the DIMM that is used for memory expansion. The JEDEC standard for the DIMM mandates that all DIMMs include a ROM with information about the memory. The Uni-N IC reads that information from that ROM by way of the I²C bus.

Open Firmware

Open Firmware is a boot environment developed using the Forth programming language. The purpose of Open Firmware is to provide a machine independent mechanism for loading operating systems from a variety of boot devices. Open Firmware probes the PCI bus looking for devices and possible Open Firmware drivers for those devices. These drivers can either be built into the Open Firmware module or located in the external device, thus providing plug and play capabilities for new boot devices. Open Firmware is capable of using these drivers to load an operating system from the device.

Functions of the Open Firmware code include

- Configuration of the Uni-N and KeyLargo ICs
- Construction of the device tree
- Probing of the devices and inclusion of some device drivers
- Selection of the boot device

On the iMac family of computers, the Open Firmware code has been extended so that the device tree describes the new hardware features of the computer. The Open Firmware code also includes FCode drivers for the new hardware channels: UltraDMA33, FireWire, and USB.

Open Firmware normally starts up using the default device and operating systems. The user can interrupt Open Firmware by holding down the Command, Option, O, and F keys. Open Firmware responds by providing a command line interface using the keyboard and built-in display. Using this interface, users can change the stored parameters used by Open Firmware.

Interrupts

The interrupt layout is determined by information in the device tree. An interrupt tree overlays the other information in the device tree and determines how the interrupts are configured.

Mac OS ROM Image File

The Mac OS ROM image file (also called the bootinfo file) is named Mac OS ROM. It includes:

- A Mac OS Loader program

Software

- A compressed Mac OS ROM image including:
 - 68K code Macintosh Toolbox code and data resources
 - PowerPC shared libraries
 - Nanokernel, the Mac OS 8 kernel
 - 68LC040 Emulator

The Nanokernel and the 68LC040 Emulator are low-level Mac OS initialization components that were part of BootPowerPC code in previous CPU ROMs. They are now included in the Mac OS ROM Image.

Complementarily, CPU-specific hardware initialization code has been relocated into the boot ROM as described in the previous section.

System Software Modifications

The following sections describe the parts of the Mac OS ROM Image that have been changed for the Mac OS 8.6 release to support features of the iMac family of computers.

Computer Identification

All ROMs based on NewWorld share the same BoxFlag. The intent is for applications to use properties in the Open Firmware device tree rather than checking BoxFlag to find out the features of the machine. As with other computers that use ROM-in-RAM, a call to `gestaltMachineType` returns the value 406 (\$196).

IMPORTANT

Programs such as control panels and installers that use Box Flag to verify that this is a valid CPU on which to execute need to be changed to verify the existence of the hardware they require. Rather than reading the box flag or the model string and then making assumptions about the computer's features, developers should look in the device tree created by Open Firmware for the features they need. ▲

Asset management software that reports the kind of machine it is run on can obtain the value of the property at `Devices:device-tree:compatible` in the name

registry. The model string is the first program-useable string in the array of C strings in the `compatible` field. For the new iMac family computers, the value of the first string in the `compatible` property is `PowerMac2`.

The string obtained from the `compatible` property cannot be displayed to the computer user. If it is available, you can use the result from calling `Gestalt('mnam', &result)` where `result` is a string pointer. This call returns a Pascal style string that can be displayed to the user.

Applications should not use either of these results to infer the presence of certain features; instead, applications should use Gestalt calls to test for the features they requires.

Power Saving Modes

The power manager has been redesigned to reduce power consumption in Sleep mode. The new version, Power Manager 2.0, is a native Mac OS manager designed to implement common power management policy across all Macintosh models by means of the new Power Plugin component.

Although the current public Power Manager interfaces will be maintained for application compatibility, this is a major revision that may affect developers. Information about the API changes for Power Manager 2.0 is available in a technote, which can be obtained from the web site at

<http://developer.apple.com/technotes/>

Here is a list of the attributes of Sleep mode on the Kihei computer.

- The main processor is off.
- Inactive systems, such as the hard drive and the sound system, are off.
- Main memory is in self-refresh mode.
- The graphics card's oscillator is off (the AGP clock is still on).
- The clocks for the KeyLargo IC are stopped.
- USB and FireWire ports are in suspend mode (the PHY ICs are still on).
- Ethernet and modem interfaces are on only if Wake-on-LAN has been selected in the Energy Saver control panel.

ATA Manager 4.0

Mac OS 8.6 includes ATA Manager 4.0, which has a modular design similar to that of SCSI Manager 4.3. With this new modular design, the ATA Manager and the ATA Interface Modules (AIMs) divide the responsibilities. The ATA Manager is responsible for

- registering ATA Interface Modules
- routing each request to the appropriate ATA Interface Modules
- calling completion routines for asynchronous calls

ATA Interface Modules are responsible for

- handling each request
- error handling
- returning errors

USB Drivers

A Universal Serial Bus Services Library layer provides hardware abstraction. Below it is the UIM (USB Interface Module) that communicates with the USB hardware in the KeyLargo IC. Above it are the class drivers that are loaded dynamically when new devices are plugged onto the bus.

USB class drivers are software components that are able to communicate with similar USB devices of a particular kind. If the appropriate class driver is present, any number of compliant devices can be plugged in and start working immediately without the need to install additional software.

Mac OS 8.6 includes the following class drivers:

- **Audio class driver:** supports USB audio devices such as speakers and microphones. The Sound Manager has been modified to control volume, mute, bass, and treble for USB speakers. Mac OS 8.6 also supports the USB Suspend and Resume functionality defined in the USB standard.
- **Mass Storage class driver:** supports booting from a USB storage device that follows the USB Mass Storage Class specification. Mass Storage Class drivers do not support CD, CD-R, or other read-only media types.
- **Communication Class driver:** Supports USB communication devices that support the Abstract Control Model subclass.

Software

- **Printer Class driver:** Supports USB printers. The LaserWriter 8 driver can communicate through this driver to any Postscript-based printer.
- **HID driver:** Provides support in InputSprockets for all HID-class devices (such as joysticks and game controllers) and for most force feedback devices.
- **Keyboard and Mouse driver:** Supports all USB keyboards and mouse devices that support boot protocol (HID Class, SubClass 1).
- **HUB Class driver:** Supports all USB compliant hubs.

Version 1.3 of the Macintosh USB system software supports all four data transfer types defined in the USB specification.

Other New Drivers

The system software includes new drivers for the FireWire ports, the Ethernet port, and the wireless LAN module.

The new FireWire Interface Module (FWIM) supports 1394 OHCI (open host controller interface). The FireWire driver also includes services for mass storage devices with the SBP-2 (Serial Bus Protocol) standard.

The new Ethernet driver supports 100Base-T operation and Wake on LAN. The Ethernet driver uses the Open Transport Data Link Provider Interface (DLPI).

The driver for the wireless LAN module is not part of the Mac OS ROM image but resides in the Extensions folder.

Legacy Drivers

The absence of serial ports, ADB ports, SCSI port, IRTalk, and floppy drive, and the addition of USB and FireWire ports, may affect the behavior and appearance of various system components. Modifications for such changes are in Mac OS 8.6 itself.

Some managers and drivers remain in the system to support existing applications that depend on those older devices. New applications are expected to use the new I/O channels such as USB and FireWire.

ADB Legacy

The iMac family computers have no ADB ports. The ADB Manager is still present, to retain compatibility with programs that require it. The system has an

Software

ADB shim layer to allow USB keyboards and mice to appear as legacy ADB devices.

SCSI Legacy

Although there is no SCSI connector on the iMac family computers, the high-level SCSI interfaces will remain in the system. That allows for possible support for SCSI devices using a USB to SCSI or FireWire to SCSI adapter. Such an adapter would take the USB or FireWire commands coming from the port and convert them into SCSI commands to send to the drive. A SCSI driver would also need to be written that would take the SCSI commands coming from the system and embed them in USB or FireWire commands that would be sent to the device through the adapter.

CHAPTER 5

Software

Abbreviations

Standard units of measure used in this developer note include:

A	amperes	MB	megabytes
dB	decibels	Mbps	megabits per second
GB	gigabytes	Mbit	megabits
Hz	hertz	MHz	megahertz
KB	kilobytes	mm	millimeters
kg	kilograms	ns	nanoseconds
kHz	kilohertz	V	volts
mA	milliamperes	VDC	volts direct current

Other abbreviations used in this note include:

\$n	hexadecimal value n
10Base-T	an Ethernet standard for data transmission at 10 Mbits per second
100Base-TX	an Ethernet standard for data transmission at 100 Mbits per second
ADB	Apple Desktop Bus
AGP	accelerated graphics port
AIM	ATA Interface Module
ANSI	American National Standards Institute
API	application programming interface
ATA	Advanced Technology Attachment
ATAPI	ATA Packet Interface
BIOS	basic input/output system
CAS	column address strobe
CD	compact disc
CD-ROM	compact disc read-only memory
CPU	central processing unit
CRM	Communications Resource Manager

APPENDIX A

Abbreviations

DAA	data access adapter
DBDMA	descriptor-based direct memory access
DIMM	Dual Inline Memory Module
DMA	direct memory access
DV	digital video
EDO	extended data out
EEPROM	electrically erasable programmable ROM
G3	Generation 3, the third generation of PowerPC microprocessors, including the PPC 740 and PPC 750
GART	graphics address remapping table
GND	ground
HFS	hierarchical file system
HID	human interface device, a class of USB devices
IC	integrated circuit
IDE	integrated device electronics
IEC	International Electrotechnical Commission
I/O	input and output
IR	infrared
ISO	International Organization for Standardization
JEDEC	Joint Electron Device Engineering Council
L1	level 1 or first level
L2	level 2 or second level
LAN	local area network
LED	light emitting diode
MAC	media access controller
Mac OS	Macintosh Operating System
modem	modulator-demodulator
NMI	nonmaskable interrupt
NV-RAM	nonvolatile random-access memory
OHCI	Open Host Controller Interface
OS	operating system

APPENDIX A

Abbreviations

PCI	Peripheral Component Interconnect
PLL	phase-locked loop
POST	power-on self test
RAM	random-access memory
RCA	Radio Corporation of America
rms	root mean square
ROM	read-only memory
RTAS	run-time abstraction services
SCC	Serial Communications Controller
SCSI	Small Computer System Interface
SDRAM	synchronous dynamic RAM
SGRAM	synchronous graphics RAM
SNR	signal to noise ratio
SPD	Serial Presence Detect
USB	Universal Serial Bus
VCC	positive supply voltage (voltage for collectors)
VIA	versatile interface adapter

A P P E N D I X A

Abbreviations

Index

A

accelerated graphics port, *See* AGP
access point. *See* base station
ADB shim layer, for USB compatibility 69
AGP bus 29
AirPort Application 43
AirPort Base Station 42
AirPort Card 42–43
 software base station 42
 software components 43
AirPort Control Strip Module 43
AirPort Setup Assistant 43
AirPort Utility 43
ATA disk interface 44
ATA Manager 4.0 67
ATI Rage IC 29

B

backside cache 27
block diagram 24, 25
boot device 62
boot process 62
boot ROM 28, 60
 contents of 63–64
 hardware initialization code in 63
box flag 65
buses 24, 26, 27

C

cache, *See* backside cache
case, *See* enclosure
CD-ROM drive 44

compatibility 20
compatibility issues
 I/O devices not present 68
computer identification 65
connectors
 Ethernet 41
 FireWire 38
 USB 34
 video monitor 46
custom ICs
 KeyLargo I/O controller 29
 Uni-N memory controller and bridge IC 27

D

device drivers 64
device tree 64
DIMMs, for RAM expansion 54
 capacities 56
 electrical design of 55
 JEDEC specifications 11, 55
 mechanical design of 55
DMA support 30
driver software 68
DVD-ROM drive 44

E

enclosure 19
Ethernet controller 29
Ethernet driver 68
Ethernet port 40
ethernet port 40
external features 19

F

features list 17
 FireWire connector 38
 FireWire controller 28
 FireWire driver 68
 FireWire ports 38

G

G3 microprocessor 26
 gestaltMachineType call 65
 graphics address remapping table (GART) 29

H

handle 19
 hard disk drive 44
 hardware initialization code 63
 headphone jacks 51

I

IDE disk interface. *See* ATA disk interface
 IDE hard disk 44
 input and output ports
 Ethernet 40
 FireWire 38
 USB 34
 video monitor 46
 internal modem 31
 interrupts 30, 64
 interrupt tree 64

J

JEDEC specifications for RAM DIMMs 11, 55

K

keyboard 47–49
 KeyLargo I/O controller IC 29

L

L2 cache 27

M

Mac OS 8.6 12
 USB transfer types supported by 67
 Mac OS ROM image file 61, 64–69
 ATA Manager in 67
 computer identification mechanism of 65
 Ethernet driver 68
 FireWire driver 68
 power saving modes 66
 SCSI interfaces in 69
 USB drivers in 67
 Mac OS software 60
 memory expansion, *See* DIMMs
 memory interleaving not supported 57
 memory sizing 63
 microprocessor 26
 model history 16
 modem 31, 41
 mouse 49

N

NewWorld software architecture
 See ROM-in-RAM

O

OHCI controller for USB 36

Open Firmware 62, 64
 command line interface of 64
 original iMac 16

P

PCI bus 29
 power controller IC 32
 power indicator 19
 Power Manager 2.0 66
 power saving modes 32, 66
 PrepareMemoryForIO function 62

R

Rage IC 29
 RAM DIMMs, *See* DIMMs
 RAM expansion 54–57
 RAM expansion, *See also* DIMMs
 RAM expansion modules, *See* DIMMs
 RAM expansion slots 54
 ROM, *See* boot ROM
 ROM in RAM 60–61
 boot ROM 60
 compatibility with applications 61
 data structures and files 61
 RAM footprint 60

S

Serial Presence Detect mechanism 63
 Sleep mode 66
 sound IC 32
 sound system 49–52
 input sources 49
 built-in microphone 50
 external input 50
 output devices 50
 external sound output 51
 headphone jacks 51

internal speakers 50
 specifications 51
 surround sound enhancements 50
 speakers 50
 Startup Disk Control Panel 61
 surround sound 50

U

UltraDMA ATA interface 67
 Uni-N memory controller and bridge IC 27
 Universal Serial Bus. *See* USB
 updates 16
 USB class drivers 67
 USB compatibility 37–38
 ADB shim for 69
 with ADB 37
 with serial ports 37
 USB controller IC 31
 USB drivers 67–68
 ADB shim for 69
 USB Interface Module with 67
 USB Services Library with 67
 USB features 35–36
 USB ports 34–38
 booting from 36
 connectors 34
 controller type 36
 data transfer speeds 31, 35
 not for LocalTalk 38
 power in Sleep mode 35
 suspend mode 36
 USB with keyboard 48

V

video connector 46
 video display 45
 controller IC 29
 subsystem architecture 29
 video monitor port 46

I N D E X

video monitors
connector for 46

W

wireless LAN driver 68
wireless LAN module 32, 42–43
base station 42
hardware components 42
security features 42
software components 43

INDEX

This Apple manual was written, edited, and composed on a desktop publishing system using Apple Macintosh computers and FrameMaker software. Line art was created using Adobe™ Illustrator and Adobe Photoshop.

Text type is Palatino® and display type is Helvetica®. Bullets are ITC Zapf Dingbats®. Some elements, such as program listings, are set in Adobe Letter Gothic.

WRITER

Allen Watson

ILLUSTRATOR

David Arrigoni

PRODUCTION EDITORS

Lorraine Findlay and Glen Frank

Special thanks to Dick Allen, Eric Anderson, Art Astrin, Dave Ferguson, Brian Girvin, Ken Gudan, John Hall, Larry Heyl, Larry Lamano, Olivier Mardinian, Paul Resch, Mike Shebanek, and Vince Wadhvani