

# iPad Air (5th generation)

## Dimensional Drawings

**Compatible with iPad Air (4th generation)**



Apple Inc.  
Copyright © 2026 Apple Inc  
All rights reserved

[Terms and Conditions \("Terms"\)](#)

These Guidelines are made available to you for informational purposes only. If you make or distribute any accessory for an Apple device based on or in connection with these Guidelines ("Accessories"), you agree to the following covenants, terms and conditions:

All intellectual property rights in and to the Guidelines, and all technology described therein, are retained by Apple Inc. ("Apple"). You acknowledge and agree that Apple is not granting you, and nothing contained herein shall constitute or be construed or interpreted as a grant, by implication, estoppel or otherwise, of any license, covenant, immunity, release or right under or with respect to any intellectual property rights of Apple, including without limitation any rights to make, use, have made, sell, import, or otherwise relating in any way to any Apple device or technology described in or relating to the Guidelines.

You agree to follow Apple's Guidelines For Using Apple Trademarks and Copyrights as published on Apple's website at [www.apple.com/legal/guidelinesfor3rdparties.html](http://www.apple.com/legal/guidelinesfor3rdparties.html) ("IP Guidelines") and as may be modified from time to time. You agree not to use the marks "Apple", the Apple Logo, "Mac", "iPhone", "iPod touch", "iPad", "Apple Watch", "WATCH" or any other marks belonging or licensed to Apple in any way except as expressly authorized in writing by Apple in each instance or as permitted in the IP Guidelines. You agree that all goodwill arising out of your authorized use of Apple's marks shall inure to the benefit of and belong to Apple.

You agree to indemnify, hold harmless, and, at Apple's option, defend, Apple against any claims, causes of action, losses, liabilities, damages, fines, settlements, costs, fees, and expenses (including attorney and other professional fees and expenses) arising out of: (i) your use of the Guidelines, including without limitation, any claims that any Accessory, or the combination of any Accessory with any software, technology, intellectual property, device, apparatus or assembly not supplied by Apple, infringes any patent, copyright, trade secret or other intellectual property right; (ii) the manufacture, use, promotion distribution, sale, offer for sale, import, other distribution or exploitation or performance of any product, case, cover, band, charging stand, or other Accessory or product incorporating any Accessory, including any personal injury or product liability claims; or (iii) any failure to comply with any of the Guidelines. You will not, without Apple's prior written consent, make any admissions of liability, enter into any settlement that imposes any obligation on Apple, or publicize any settlement details relating to Apple. In addition, for any claims related to these Terms where you do not have an indemnification obligation, you shall provide all reasonable assistance to Apple and/or its counsel in connection with the defense, remedy or mitigation of such claims.

Applicable laws or regulations may impose additional restrictions or requirements on Accessories or products that incorporate the Accessories. You represent and warrant that you are in full compliance with all applicable laws, regulations, and policies in the United States and in any other location in which you engage, in whole or in part, in any activity related to the design, manufacture, marketing, sale or offer for sale, use, or other distribution of Accessories or products that incorporate the Accessories. You agree to promptly notify Apple of any complaints or threats of complaints regarding products that incorporate the Accessories with respect to any such regulatory requirements, in which case Apple may limit or terminate your ability to make, sell or purchase additional Accessories.

You expressly acknowledge and agree that access to the Guidelines is at your sole and entire risk and that you are solely responsible and liable for any harm or damage to any Apple product arising out of any breach by you of these covenants, terms and conditions. THE GUIDELINES ARE PROVIDED "ASIS" AND WITHOUT REPRESENTATION, WARRANTY, UPGRADES OR SUPPORT OF ANY KIND. APPLE AND APPLE'S DISTRIBUTORS, AFFILIATES, LICENSOR(S) AND SUPPLIER(S) ("APPLE PARTIES") EXPRESSLY DISCLAIM ALL REPRESENTATIONS, WARRANTIES AND CONDITIONS, EXPRESS OR IMPLIED, INCLUDING THE IMPLIED WARRANTIES AND CONDITIONS OF MERCHANTABILITY, OF SATISFACTORY QUALITY, OF FITNESS FOR A PARTICULAR PURPOSE, OF NON-INFRINGEMENT AND OF ACCURACY. NONE OF THE APPLE PARTIES WARRANTS THAT THE GUIDELINES OR ANY ACCESSORY WILL MEET YOUR REQUIREMENTS, THAT DEFECTS IN THEM WILL BE CORRECTED OR THAT THEY WILL BE COMPATIBLE WITH FUTURE APPLE PRODUCTS. NO ORAL OR WRITTEN INFORMATION OR ADVICE GIVEN BY ANY APPLE PARTY OR AN APPLE AUTHORIZED REPRESENTATIVE WILL CREATE A WARRANTY.

EXCEPT TO THE EXTENT SUCH A LIMITATION IS PROHIBITED BY LAW, IN NO EVENT WILL ANY APPLE PARTY BE LIABLE FOR ANY INCIDENTAL, SPECIAL, INDIRECT, CONSEQUENTIAL, EXEMPLARY OR PUNITIVE DAMAGES, INCLUDING LOST PROFITS, LOST REVENUES OR BUSINESS INTERRUPTIONS, ARISING OUT OF OR RELATING TO THE GUIDELINES UNDER A THEORY OF CONTRACT, WARRANTY, TORT (INCLUDING NEGLIGENCE), PRODUCTS LIABILITY OR OTHERWISE, EVEN IF ANY APPLE PARTY HAS BEEN ADVISED OF THE POSSIBILITY OF SUCH DAMAGES, AND NOTWITHSTANDING THE FAILURE OF ESSENTIAL PURPOSE OF ANY REMEDY. IN NO EVENT WILL THE APPLE PARTIES' TOTAL LIABILITY TO YOU FOR ALL DAMAGES AND CLAIMS UNDER OR RELATED TO THE GUIDELINES EXCEED THE AMOUNT OF US\$50.00

These Terms will be governed by and construed and enforced under the laws of the United States and the State of Delaware, except that the arbitration clause and any arbitration hereunder shall be governed by the Federal Arbitration Act, Chapters 1 and 2. The United Nations Convention on Contracts for the International Sale of Goods shall not apply to these Terms. All disputes arising out of or in connection with these Terms shall be finally settled under the Rules of Arbitration of the International Chamber of Commerce by one arbitrator appointed in accordance with such rules, and shall be conducted according to the International Bar Association Rules on the Taking of Evidence in International Arbitration. The arbitration shall take place in San Francisco, California. The arbitration shall be conducted in English. The award shall be rendered within six months of the commencement of the arbitration, unless the arbitrator determines that the interest of justice requires that such limit be extended.

**NOTES:** (UNLESS OTHERWISE SPECIFIED)

- 1 DO NOT OBSTRUCT ACOUSTIC OPENINGS: SIDE MIC, REAR MIC, SPEAKERS
- 2 DO NOT OBSTRUCT IMAGING FEATURES: FRONT CAMERA, REAR CAMERA
- 3 DO NOT OBSTRUCT AMBIENT LIGHT SENSOR (ALS)
- 4 DO NOT OBSTRUCT SLEEP/WAKE BUTTON
- 5 DO NOT OBSTRUCT GLASS WITH METAL
- 6 DO NOT OBSTRUCT ENCLOSURE WITH METAL

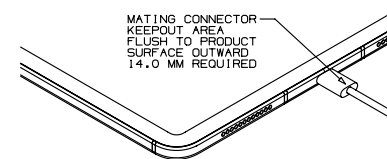
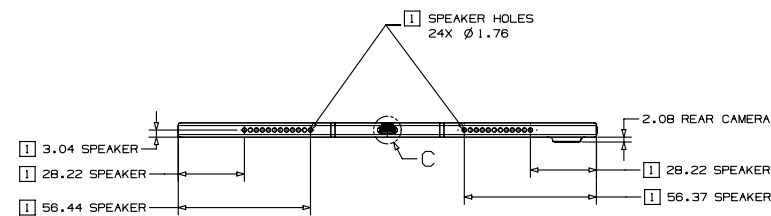
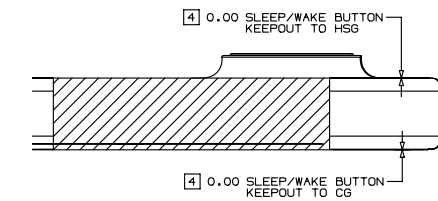
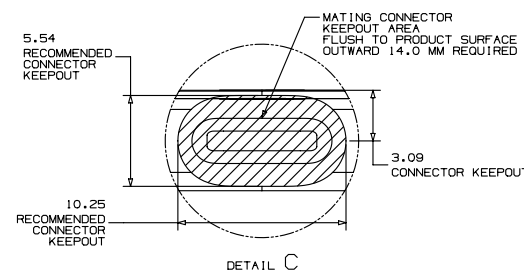
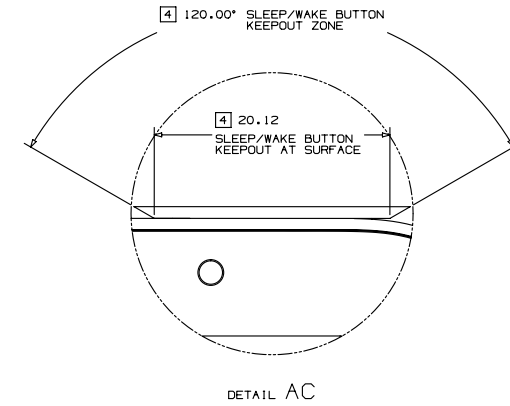
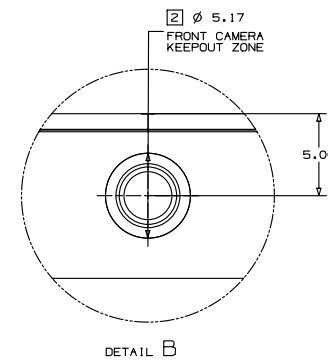
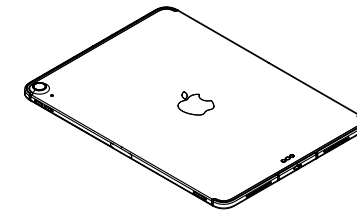
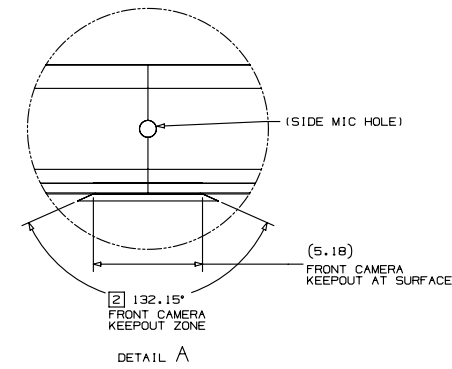
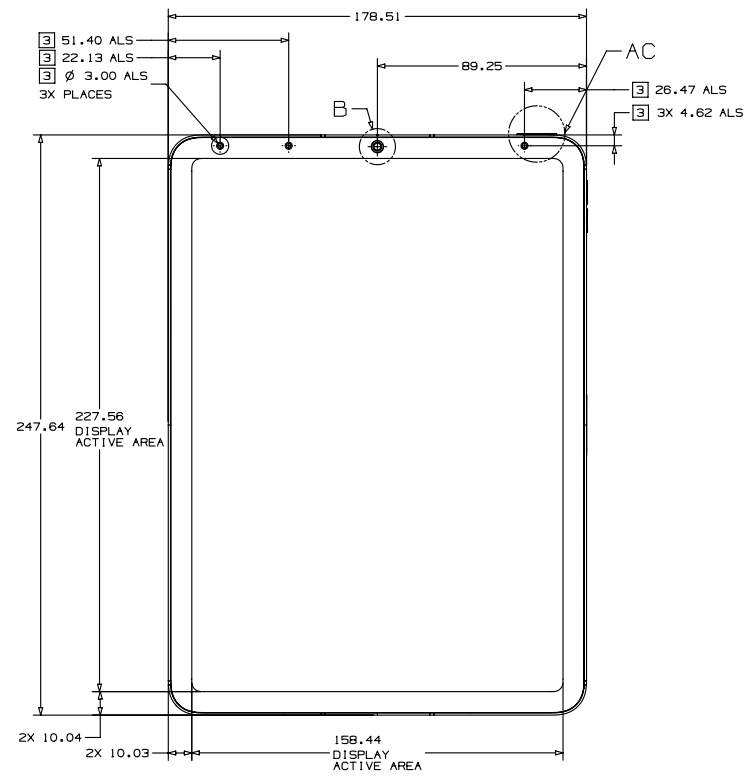
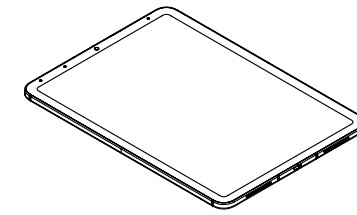
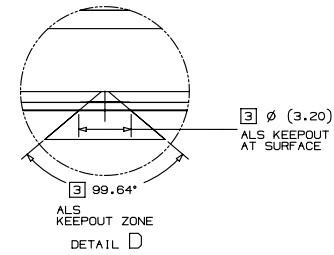
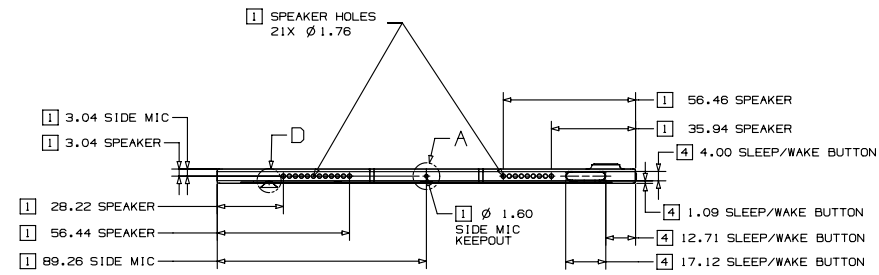

METRIC		Apple Inc.	
DESIGNER	DATE	NOTICE OF PROPRIETARY PROPERTY	
APPLE		THE FOLLOWING IS THE PROPERTY OF APPLE INC. THE POSSESSION AND USE OF THIS DOCUMENT IS RESTRICTED TO THE INDIVIDUALS AND DEPARTMENTS SPECIFICALLY IDENTIFIED IN THIS DOCUMENT. IT IS NOT TO BE REPRODUCED OR COPIED IN WHOLE OR PART WITHOUT THE WRITTEN PERMISSION OF APPLE INC. ALL RIGHTS RESERVED.	
DESIGNER	DATE	TITLE	
APPLE		iPad Air (5th generation) iPad Air (4th generation)	
DIMENSIONS ARE IN MILLIMETERS		DRAWING NUMBER	REV. 01
TOLERANCES			
X.X	±0.2		
X.XX	±0.10		
X.XXX	±0.050		
ANGLES ±0.5°			
DO NOT SCALE DIMENSIONS			
THIRD ANGLE PROJECTION	SCALE NONE	SHEET 1 OF 5	

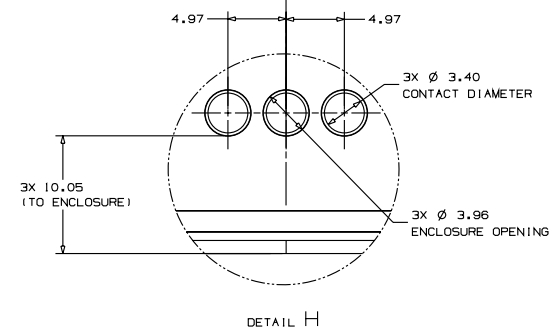
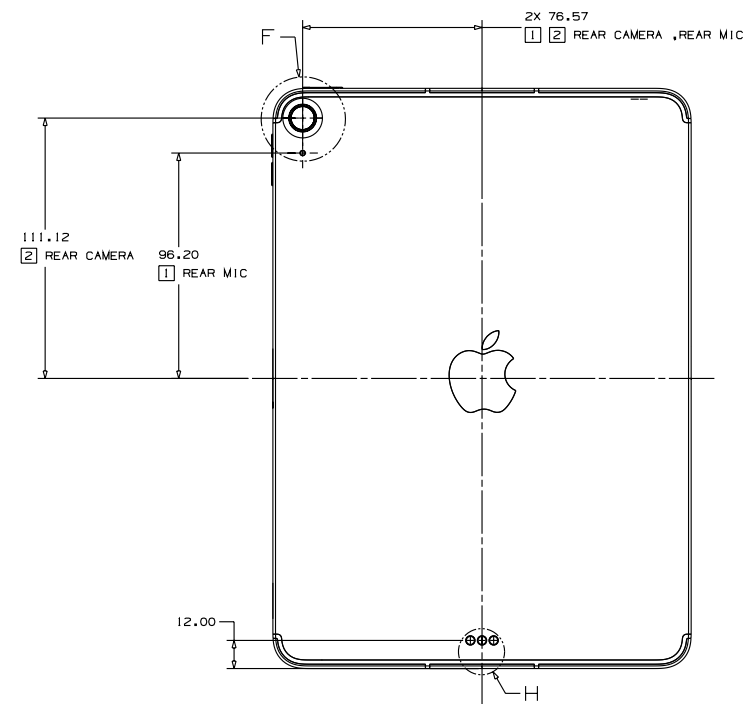
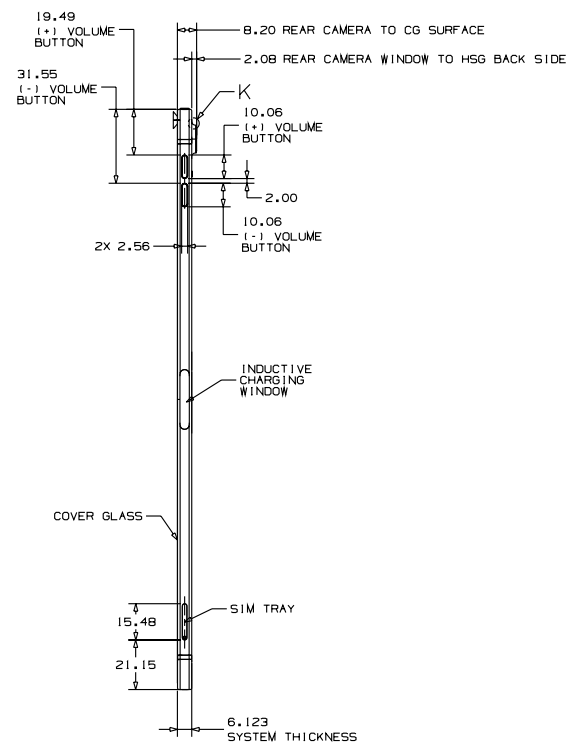
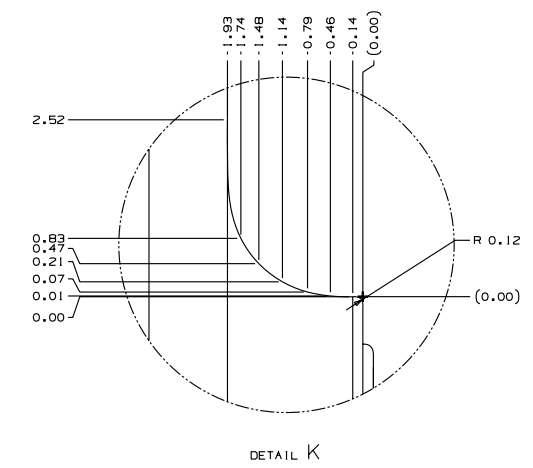
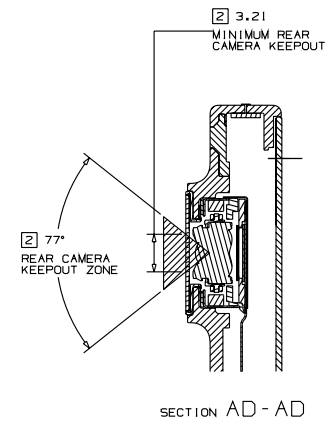
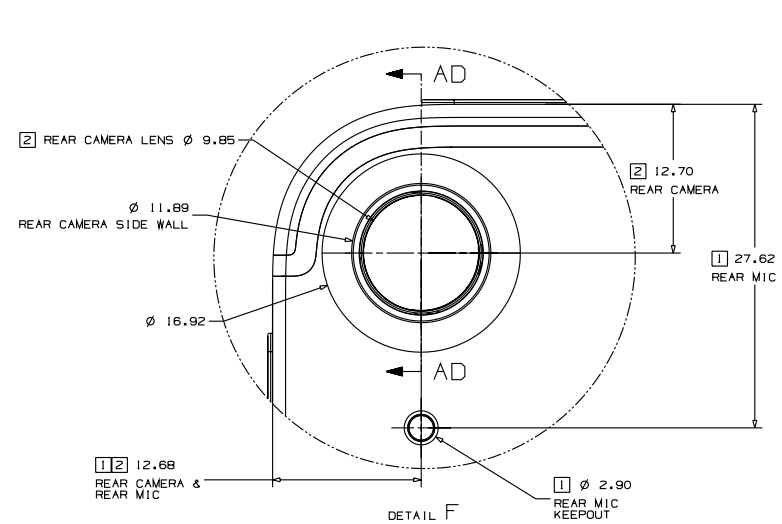

NOTICE OF PROPRIETARY PROPERTY: THE INFORMATION CONTAINED HEREIN IS THE PROPRIETARY PROPERTY OF APPLE INC. THE PROCEEDING HERETO IS UNCLASSIFIED.		Apple Inc.	
SIZE	DRWG NUMBER	REV.	
E			
SCALE	NONE		
	SHEET 2 OF 5		

# MAGNET DETAIL

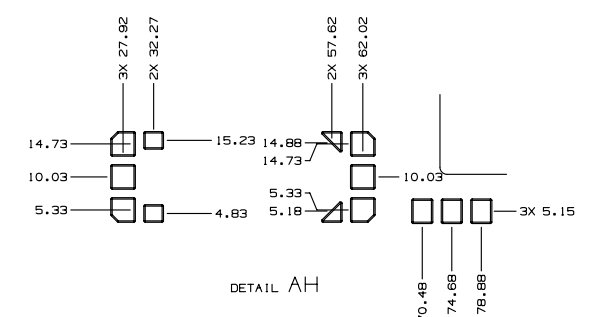
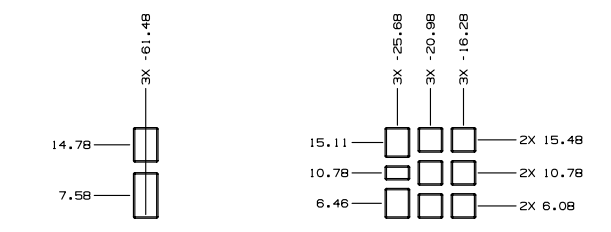
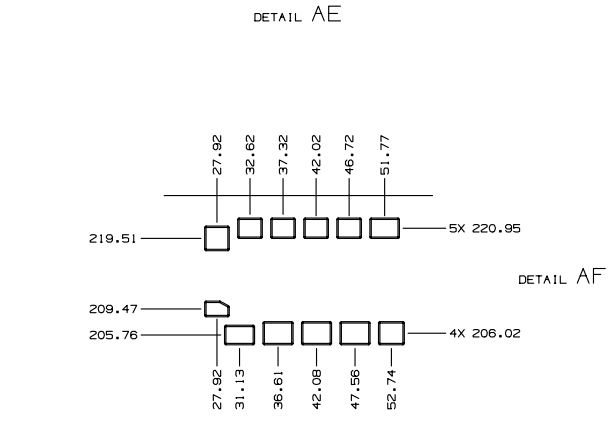
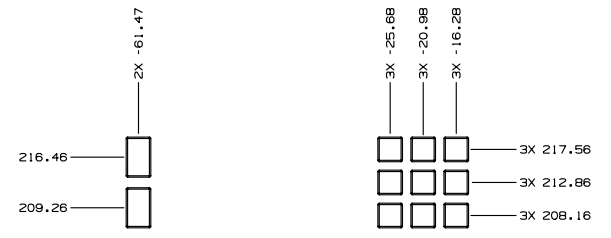
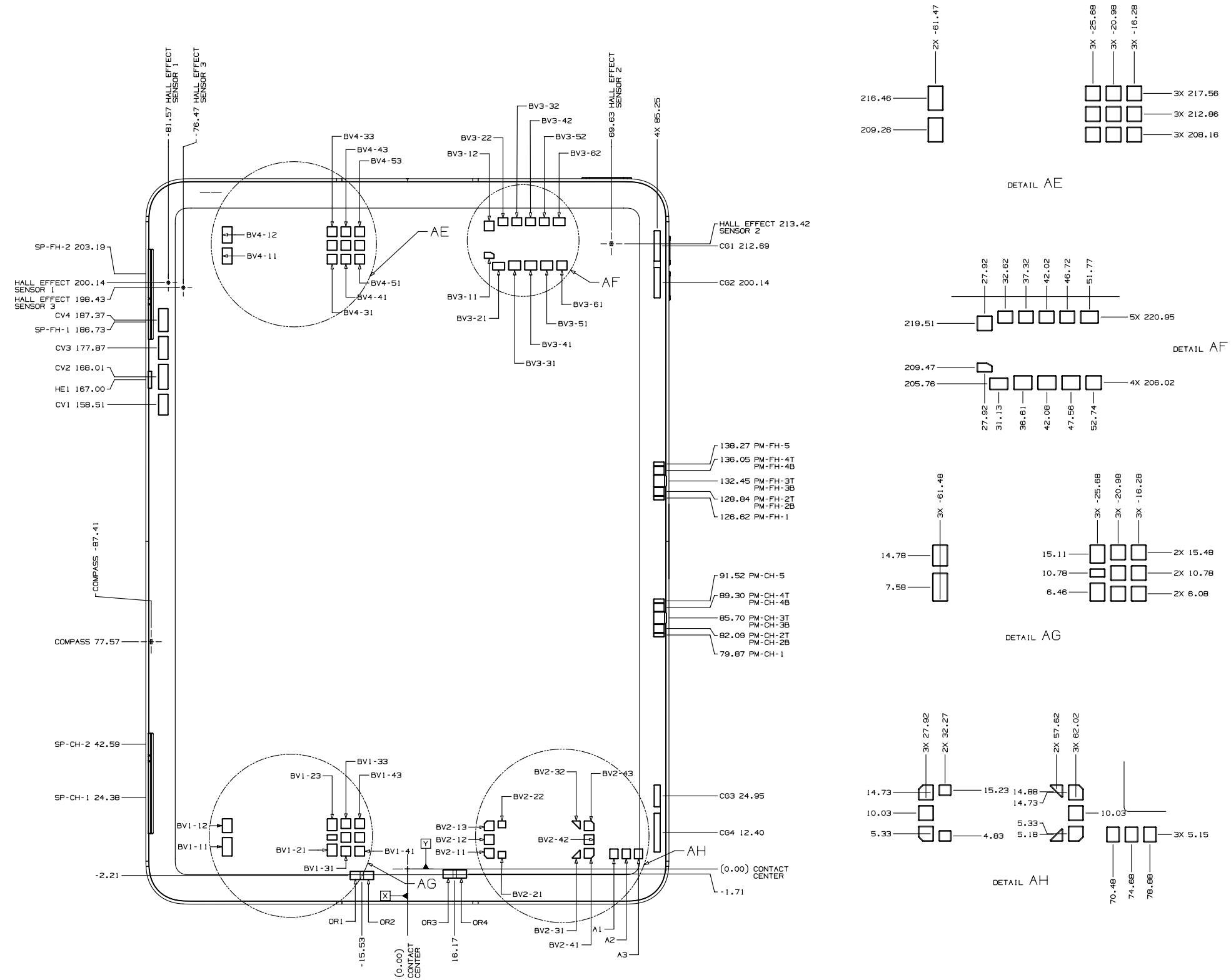

LOCATION	POLARITY TOWARD OUTER COSMETIC SURFACE OF ENCLOSURE	POLARITY TOWARD INSIDE OF PRODUCT
BV1-11	N	S
BV1-12	S	N
BV1-21	S	N
BV1-22	N	S
BV1-23	S	N
BV1-31	N	S
BV1-32	S	N
BV1-33	N	S
BV1-41	N	S
BV1-42	N	S
BV1-43	S	N
BV2-11	N	S
BV2-12	N	S
BV2-13	S	N
BV2-21	S	N
BV2-22	N	S
BV2-31	S	N
BV2-32	S	N
BV2-41	N	S
BV2-42	S	N
BV2-43	N	S
BV3-11	S	N
BV3-12	N	S
BV3-21	N	S
BV3-22	S	N
BV3-31	S	N
BV3-32	N	S
BV3-41	N	S
BV3-42	S	N
BV3-51	S	N
BV3-52	S	N
BV3-61	N	S
BV3-62	N	S
BV4-11	S	N
BV4-12	N	S
BV4-31	S	N
BV4-32	N	S
BV4-33	S	N
BV4-41	N	S
BV4-42	S	N
BV4-43	S	N
BV4-51	S	N
BV4-52	N	S
BV4-53	N	S
CV1	S	N
CV2	N	S
CV3	N	S
CV4	S	N
OR1	S	N
OR2	N	S
OR3	N	S
OR4	S	N
PM-FH-1	S	N
PM-FH-2	S	N
SP-CH-1-S	S	N
SP-CH-1-B	N	S
SP-CH-2-S	N	S
SP-CH-2-B	S	N
SP-FH-1-S	N	S
SP-FH-1-B	S	N
SP-FH-2-S	S	N
SP-FH-2-B	N	S
A1	S	N
A2	N	S
A3	S	N

NOTICE OF PROPRIETARY PROPERTY:  
 THE INFORMATION CONTAINED HEREIN IS THE PROPRIETARY PROPERTY OF APPLE INC. THE INFORMATION IS NOT TO BE RELEASED OR PUBLISHED IN WHOLE OR IN PART WITHOUT THE WRITTEN PERMISSION OF APPLE INC.  
 SCALE: NONE  
 SHEET: 3 OF 5

# SECTION AND DETAIL INFORMATION

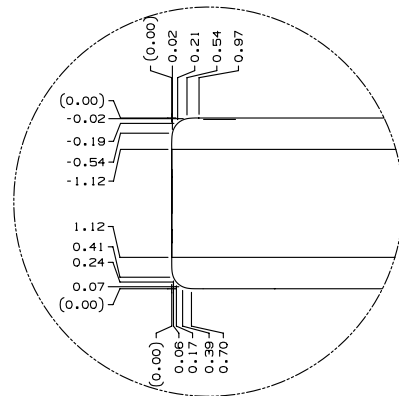

DETAIL N

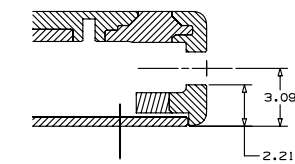
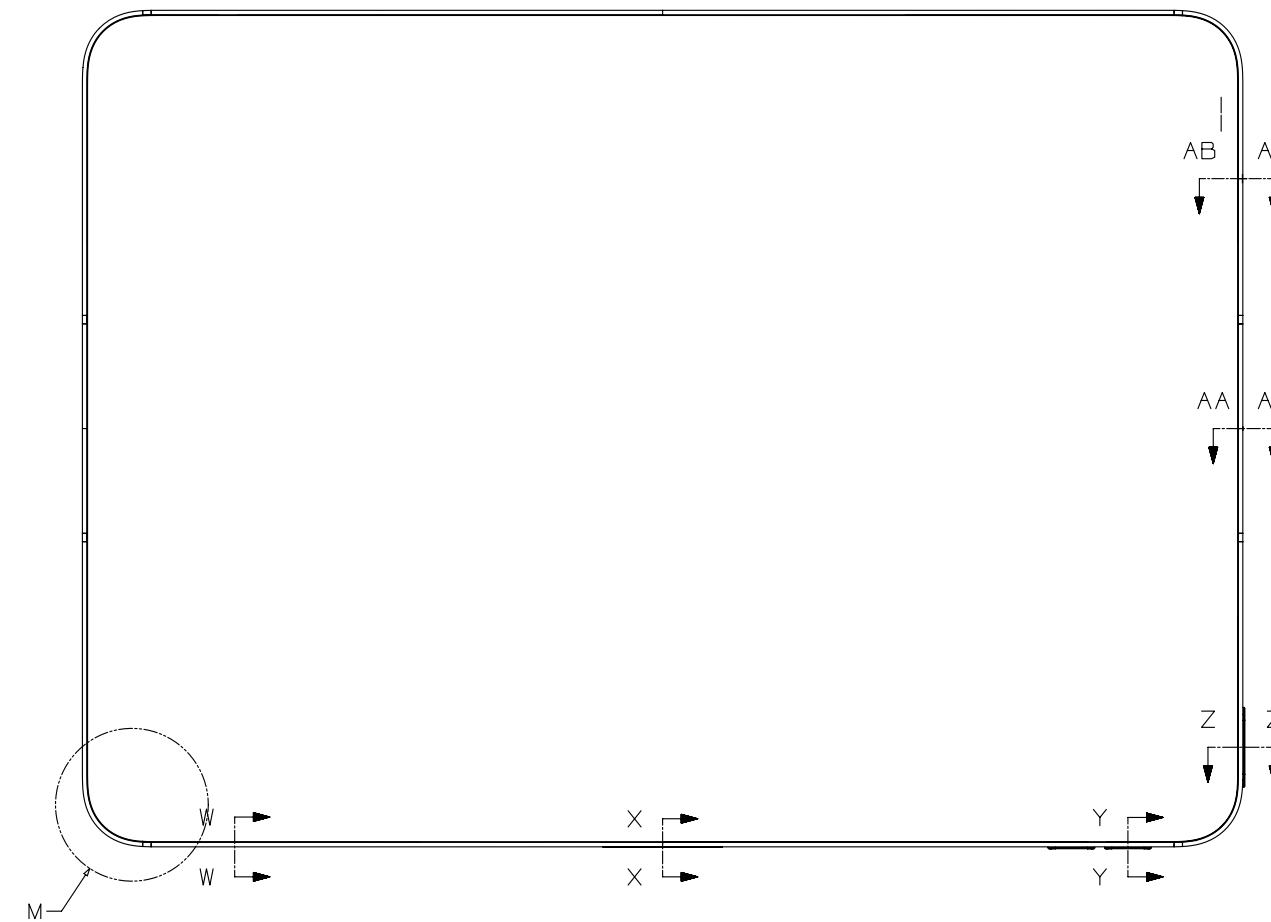
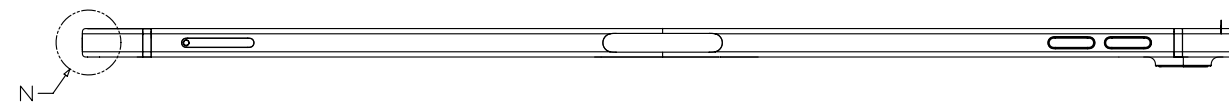

SECTION AB-AB  
SPEAKER HOLES

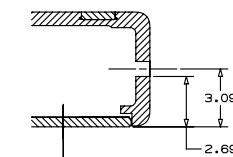

SECTION AA-AA  
SIDE MIC HOLE

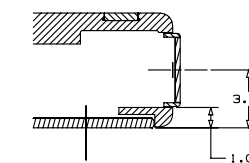

SECTION Z-Z  
SLEEP/WAKE BUTTON

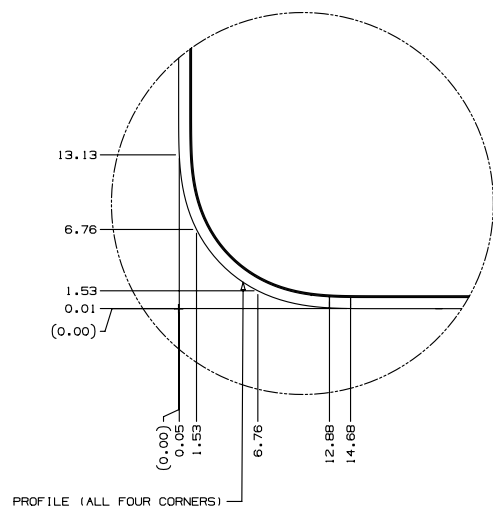

PROFILE (ALL FOUR CORNERS)  
DETAIL M

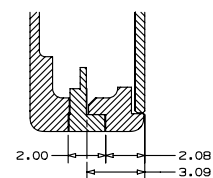

SECTION W-W  
SIM TRAY  
(CELLULAR ONLY)

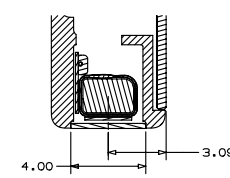

SECTION X-X  
INDUCTIVE CHARGING  
WINDOW FOR PENCIL

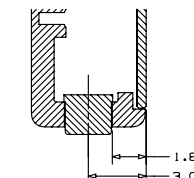

SECTION Y-Y  
VOLUME BUTTONS

<small>NOTICE OF PROPRIETARY PROPERTY: THE INFORMATION CONTAINED HEREIN IS THE PROPRIETARY PROPERTY OF APPLE INC. THE PROPRIETARY RIGHTS TO THE FOLLOWING: 1) IT IS INTENDED TO BE SHOWN IN CONFIDENCE 2) IT IS NOT TO BE REPRODUCED OR TRANSMITTED IN ANY FORM OR BY ANY MEANS 3) IT IS NOT TO BE DISCLOSED OR PUBLISHED IN WHOLE OR IN PART 4) ALL RIGHTS ARE RESERVED.</small>		
<small>SIZE</small> E	<small>DRAWING NUMBER</small> 	<small>REV.</small> 
<small>SCALE</small> NONE	<small>SHEET</small> 4	<small>OF</small> 5

# ANTENNA KEEPOUT

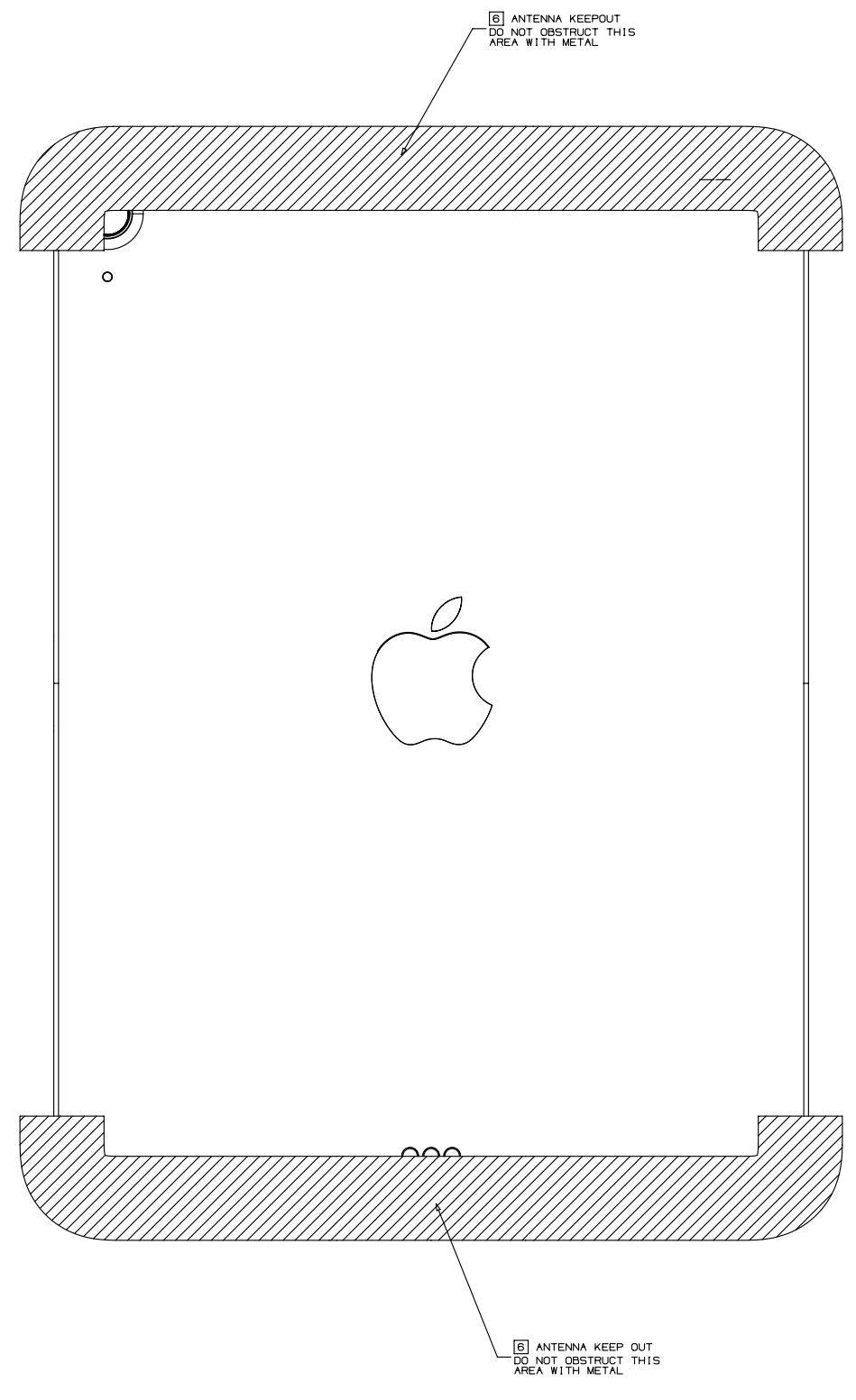
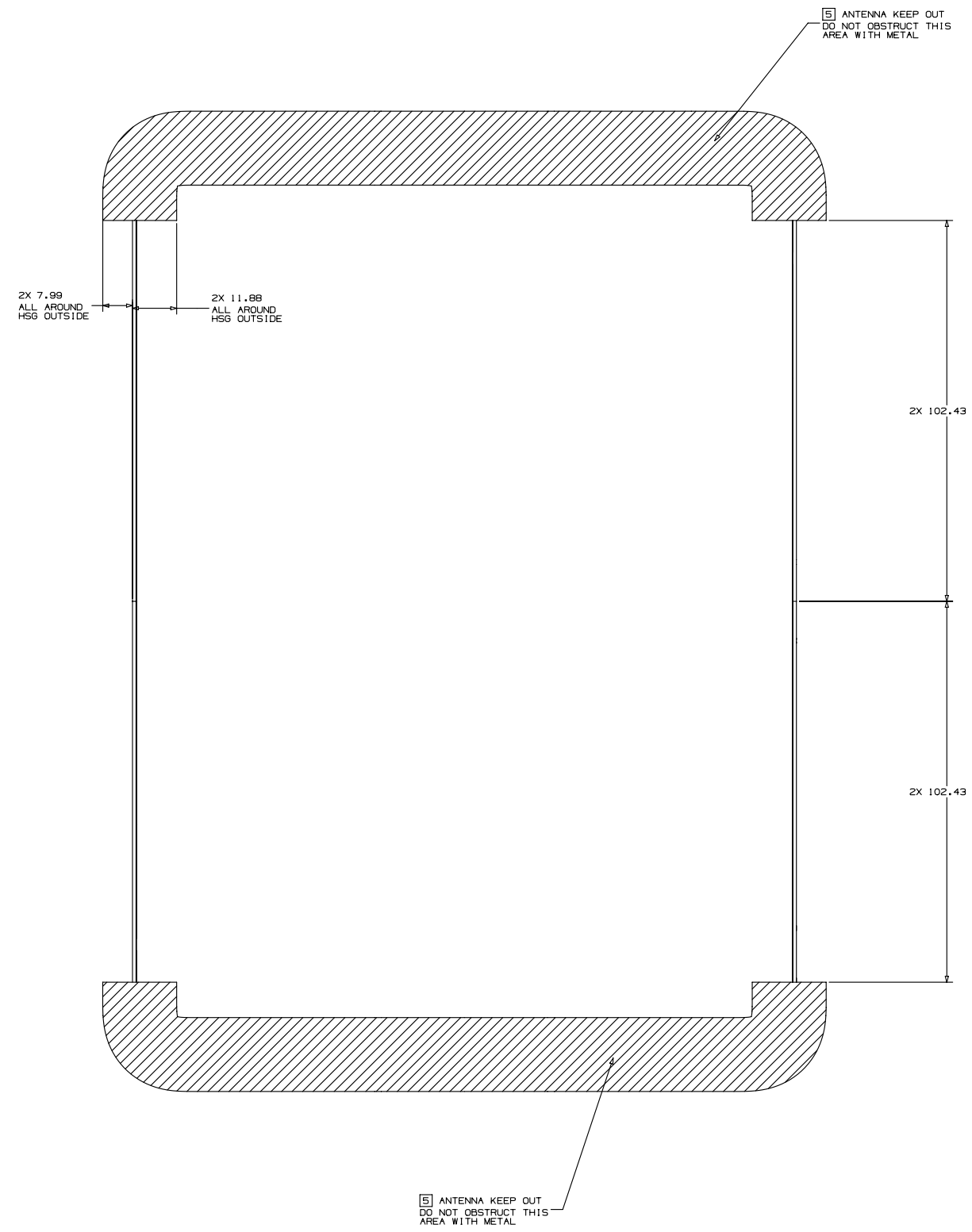

NOTICE OF PROPRIETARY PROPERTY:  
THE INFORMATION CONTAINED HEREIN IS THE PROPRIETARY  
PROPERTY OF APPLE INC. THE INFORMATION IS TO BE  
USED ONLY FOR THE PURPOSES SPECIFIED IN THIS DOCUMENT IN CONFIDENCE  
AND IS NOT TO BE REPRODUCED, COPIED, OR PUBLISHED IN ANY MANNER  
WITHOUT THE EXPRESS WRITTEN PERMISSION OF APPLE INC. ALL RIGHTS RESERVED.

Apple Inc.

SIZE	DRWING NUMBER	REV.
E		
SCALE	NONE	
	REV 5 OF 5	